

## LM5033 100V Push-Pull Voltage Mode PWM Controller

Check for Samples: [LM5033](#)

### FEATURES

- Internal High Voltage (100V) Start-Up Regulator
- Single Resistor Oscillator Setting
- Synchronizable
- Precision Reference Output
- Adjustable Soft-Start
- Over-Current Protection
- Direct Optocoupler Interface
- 1.5A Peak Gate Drivers
- Thermal Shutdown

### APPLICATIONS

- Intermediate DC/DC Bus Converter
- Telecommunication Power Converters
- Industrial Power Converters
- +42V Automotive Systems

### PACKAGE

- VSSOP-10
- WSON-10

### DESCRIPTION

The LM5033 High Voltage PWM controller contains all the features needed to implement Push-Pull, Half-Bridge, and Full-Bridge topologies. Applications include closed loop voltage mode converters with a highly regulated output voltage, or an open loop "DC transformer" such as an Intermediate Bus Converter (IBC) with an efficiency >95%. Two alternating gate driver outputs with a specified deadtime are provided. The LM5033 includes a start-up regulator that operates over a wide input range of 15V to 100V. Additional features include: precision voltage reference output, current limit detection, remote shutdown, softstart, sync capability and thermal shutdown. This high speed IC has total propagation delays less than 100 ns and a 1MHz capable oscillator.

### Connection Diagram

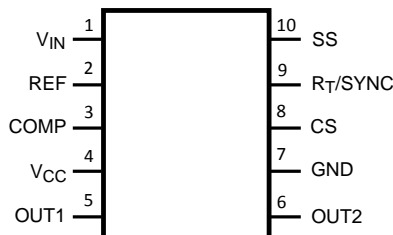

**Figure 1. 10-Lead VSSOP, WSON  
Package Number DGS0010A, DPR0010A**



Please be aware that an important notice concerning availability, standard warranty, and use in critical applications of Texas Instruments semiconductor products and disclaimers thereto appears at the end of this data sheet.

All trademarks are the property of their respective owners.

### PIN DESCRIPTIONS

PIN	NAME	DESCRIPTION	APPLICATION INFORMATION
1	Vin	Input Voltage	Input to the start-up regulator. Input range is 15V to 90V, with transient capability to 100V .
2	REF	2.5V precision reference output	Sink only, requires an external pull-up resistor. This can be used as a reference for external circuitry.
3	COMP	PWM Input	Feedback to the PWM comparator's inverting input, through a 3:1 divider. The output duty cycle increases as this pin's voltage increases. Internally there is a 5k $\Omega$ pullup to +5.2V.
4	VCC	9.6V output from the internal high voltage series pass regulator	An external voltage (10V - 15V) can be applied to this pin to shutdown the internal regulator, thereby reducing internal dissipation. An internal diode connects Vcc to Vin.
5	OUT1	Gate Driver Output #1	Alternating output gate driver, which can source and sink 1.5A.
6	OUT2	Gate Driver Output #2	Alternating output gate driver, which can source and sink 1.5A.
7	GND	Ground pin for all internal circuitry	Connections to external ground must be done with care for optimum performance. See the <a href="#">Functional Description</a> and <a href="#">Application Information</a> Section for more information.
8	CS	Current sense input	Current sense input for the current limit detection. If CS exceeds 0.5V the outputs are disabled and the softstart pin is discharged to ground.
9	R <sub>T</sub> / SYNC	Oscillator timing resistor pin and synchronization input	An external resistor to ground sets the oscillator frequency. This pin will also accept ac-coupled synchronization pulses from an external source.
10	SS	Softstart pin	An internal 10 $\mu$ A current source and an external capacitor set the soft-start timing. This pin can be externally pulled to below 0.5V to disable the output drivers.
WSON DAP	SUB	Die Substrate	The exposed die attach pad on the WSON package should be connected to a PCB thermal pad at ground potential. For additional information on using Texas Instruments's No Pull Back WSON package, please refer to Application Note AN-1187.

## Block Diagram

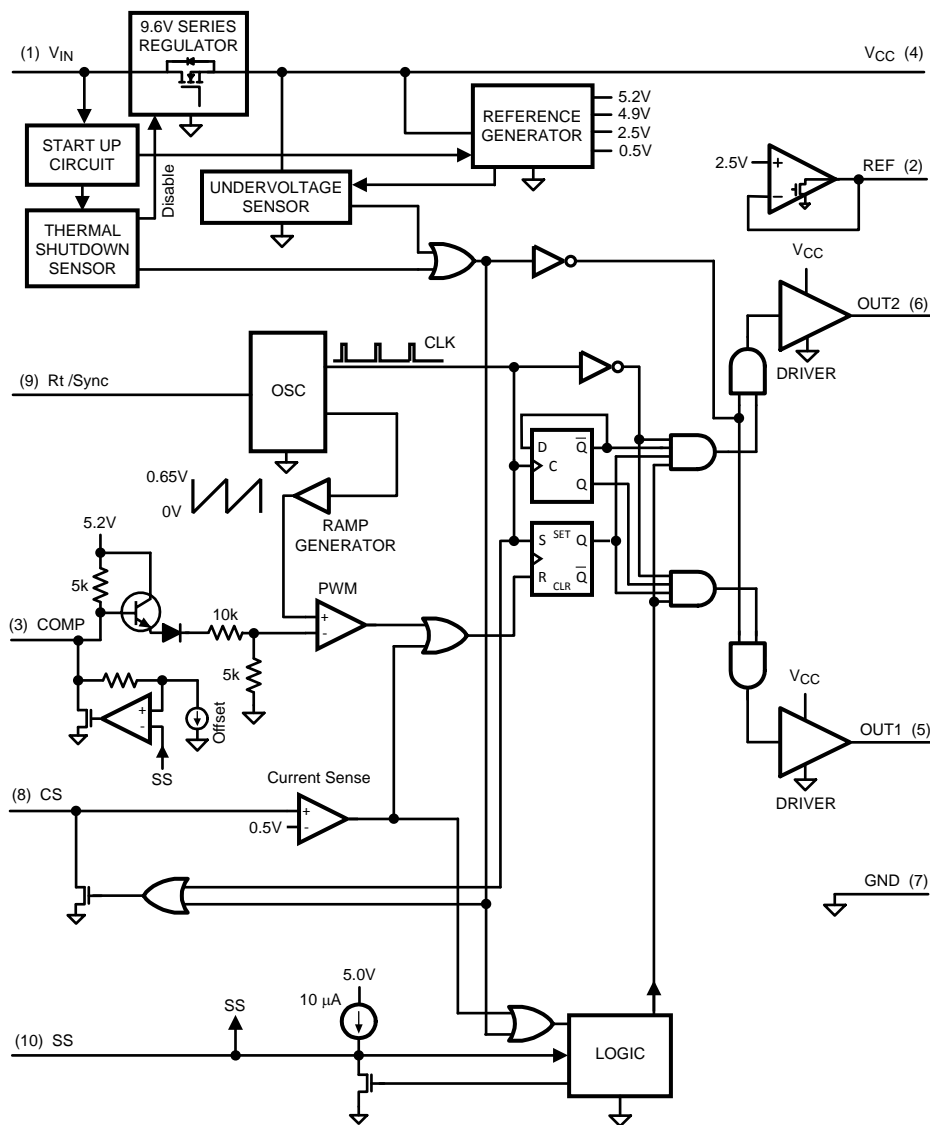

Figure 2. Functional Block Diagram



These devices have limited built-in ESD protection. The leads should be shorted together or the device placed in conductive foam during storage or handling to prevent electrostatic damage to the MOS gates.

## Absolute Maximum Ratings <sup>(1)(2)</sup>

$V_{IN}$ to GND	-0.3V to 100V
$V_{CC}$ to GND	-0.3V to 16V
Rt/Sync to GND	-0.3V to 5.5V
Pins 3, 8, 10 to GND	-0.3V to 7.0V
ESD Rating <sup>(3)</sup>	
Human Body Model	2kV
Storage Temperature Range	-65°C to 150°C
Junction Temperature	150°C
Power Dissipation <sup>(4)</sup>	Internally Limited

- (1) Absolute Maximum Ratings are limits beyond which damage to the device may occur. Operating Ratings are conditions under which operation of the device is intended to be functional. For specifications and test conditions, see the Electrical Characteristics.
- (2) If Military/Aerospace specified devices are required, please contact the Texas Instruments Sales Office/ Distributors for availability and specifications.
- (3) The human body model is a 100 pF capacitor discharged through a 1.5kΩ resistor into each pin.
- (4) The maximum allowable power dissipation is a function of the maximum allowed junction temperature ( $T_{J(max)}$ ), the ambient temperature ( $T_A$ ), and the junction-to-ambient thermal resistance ( $\theta_{JA}$ ). The maximum allowable power dissipation can be calculated from  $PD = (T_{J(max)} - T_A) / \theta_{JA}$ . Excessive power dissipation will cause the thermal shutdown to activate.

## Operating Ratings <sup>(5)</sup>

$V_{IN}$ Voltage (Pin1)	15 to 90V
Operating Junction Temperature	-40°C to 125°C

- (5) Absolute Maximum Ratings are limits beyond which damage to the device may occur. Operating Ratings are conditions under which operation of the device is intended to be functional. For specifications and test conditions, see the Electrical Characteristics.

## Electrical Characteristics

Specifications with standard typeface are for  $T_J = 25^\circ\text{C}$ , and those with **boldface** type apply over full **Operating Junction Temperature range**.  $V_{IN} = 48\text{V}$ ,  $V_{CC} = 10\text{V}$  applied externally,  $R_T = 26.7\text{k}\Omega$ , unless otherwise stated. See <sup>(1)</sup> and <sup>(2)</sup>.

Symbol	Parameter	Conditions	Min	Typ	Max	Units
<b><math>V_{CC}</math> Startup Regulator (Pins 1, 4)</b>						
$V_{CCReg}$	$V_{CC}$ Voltage	Pin 4 open	<b>9.2</b>	9.6	<b>10.0</b>	V
icc-out	$V_{CC}$ Current Limit	Out1, Out2 disabled. Ext. supply to $V_{CC}$ disconnected.	<b>20</b>	34		mA
iin	Startup Regulator Current into $V_{IN}$	Normal Operation $V_{IN} = 90\text{V}$		150	<b>500</b>	$\mu\text{A}$
		Ext. $V_{CC}$ Supply Disconnected and Output Load = 1800pF		7		mA
		SS Pin = 0V		3		mA
UVT	$V_{CC}$ Undervoltage Threshold (increasing $V_{CC}$ )		<b>VccReg - 300mV</b>	$V_{CCReg} - 100\text{mV}$		V
	UVT Hysteresis (decreasing $V_{CC}$ )		<b>2.3</b>	2.8	<b>3.3</b>	
icc-in	Supply Current from external source to $V_{CC}$	SS Pin = 0V		2	<b>3</b>	mA
		SS Pin = open and Output Load = 1800pF		7		
<b>2.5V Reference (Pin 2)</b>						
Vref	Output voltage	Pin 2 sink current = 5mA	<b>2.44</b>	2.50	<b>2.56</b>	V
	Current sink capability		<b>5.0</b>	13		mA
<b>Current Sense (Pin 8)</b>						
CS	Threshold voltage		<b>0.45</b>	0.50	<b>0.55</b>	V

- (1) Min and Max limits are 100% production tested at 25°C. Limits over the operating temperature range are specified through correlation using Statistical Quality Control (SQC) methods. Limits are used to calculate TI's Average Outgoing Quality Level (AOQL).
- (2) Typical specifications represent the most likely parametric norm at 25°C operation.

## Electrical Characteristics (continued)

Specifications with standard typeface are for  $T_J = 25^\circ\text{C}$ , and those with **boldface** type apply over full **Operating Junction Temperature range**.  $V_{IN} = 48\text{V}$ ,  $V_{CC} = 10\text{V}$  applied externally,  $R_T = 26.7\text{k}\Omega$ , unless otherwise stated. See <sup>(1)</sup> and <sup>(2)</sup>.

Symbol	Parameter	Conditions	Min	Typ	Max	Units
	CS delay to output	Pin 8 taken from zero to 0.6V. Time for Out1 or Out2 to fall to 90% of $V_{CC}$ . $C_{Load} = 0 @ \text{Out1, Out2}$		30		ns
	Current sink capability (clocked)	Pin 8 $\leq 0.3\text{V}$	<b>3</b>	6		mA
<b>Softstart (Pin 10)</b>						
	Softstart current source		<b>7</b>	10	<b>13</b>	$\mu\text{A}$
	Softstart to Comp offset		<b>0.25</b>	0.50	<b>0.75</b>	V
	Open Circuit Voltage			5.0		V
<b>Oscillator (Pin 9)</b>						
Fs1	Internal frequency	$R_T = 26.7\text{ k}\Omega$	<b>175</b>	200	<b>225</b>	kHz
Fs2	Internal frequency	$R_T = 8.2\text{ k}\Omega$		600		kHz
Vsync	Sync threshold			3.2	<b>3.8</b>	V
	$R_i/\text{Sync DC voltage}$			2.0		V
<b>PWM Comparator Input (Pin 3)</b>						
$t_{\text{PWM}}$	Gain from pin 3 to PWM comparator			0.34		V/V
	Maximum duty cycle at Out1, Out2	See <a href="#">PWM Comparator</a> text		$100 \times (0.5T_S - T_D)/T_S$		%
	Minimum duty cycle at Out1, Out2	Pin 3 = 0V.			<b>0</b>	%
	Open Circuit Voltage		<b>4.2</b>	5.2	<b>6.2</b>	V
	Short circuit current	Pin 3 = 0V	<b>0.6</b>	1.1	<b>1.5</b>	mA
<b>Output Drivers (Pin 5, 6)</b>						
	Deadtime ( $T_D$ )	$C_{Load} = 0 @ \text{OUT1, OUT2}$ . Time measured from 10% of falling output to 10% of rising output.	<b>85</b>	135	<b>185</b>	ns
	Rise Time	$C_{Load} = 1\text{ nF}$		16		ns
	Fall Time	$C_{Load} = 1\text{ nF}$		16		ns
	Output High Voltage	$I_{out} = 50\text{ mA (source)}$	<b><math>V_{CC} - 0.75</math></b>	$V_{CC} - 0.25$		V
	Output Low Voltage	$I_{out} = 100\text{ mA (sink)}$		0.25	<b>0.75</b>	V
	Max. source current			1.5		A
	Max. sink current			1.5		A
<b>Thermal Shutdown</b>						
$T_{SD}$	Shutdown temperature			165		$^\circ\text{C}$
	Shutdown temperature hysteresis			15		$^\circ\text{C}$
<b>Thermal Resistance</b>						
$\theta_{JA}$	Junction to Ambient	DGS0010A Package		200		$^\circ\text{C/W}$
		DPR0010A Package		38		

Typical Performance Characteristics

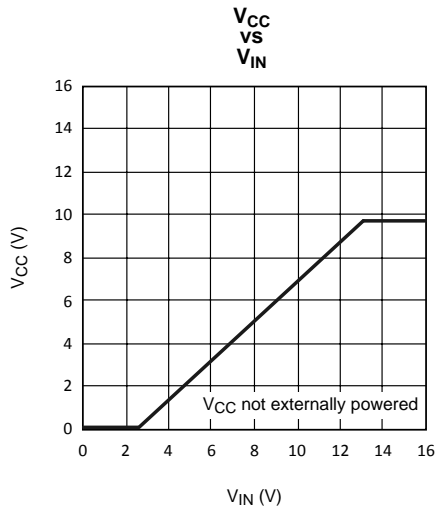

Figure 3.

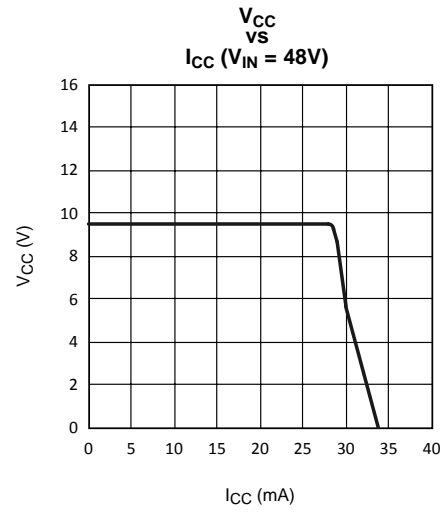

Figure 4.

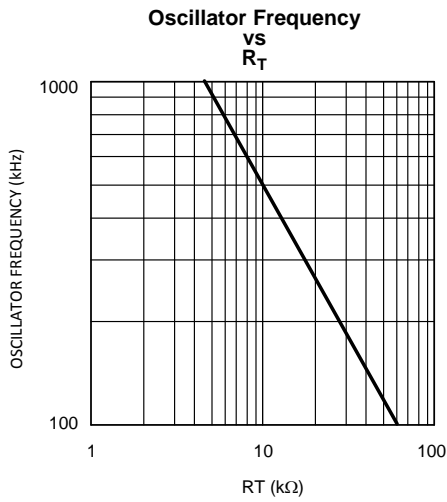

Figure 5.

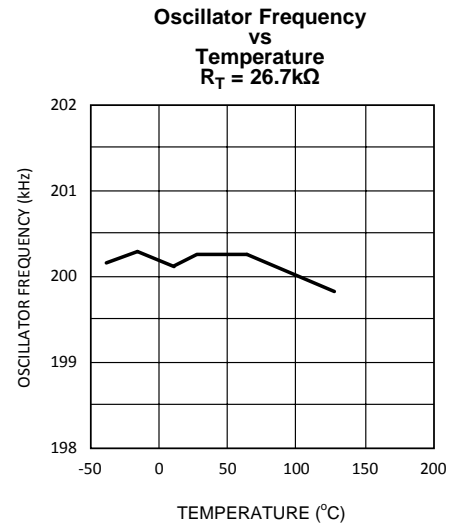

Figure 6.

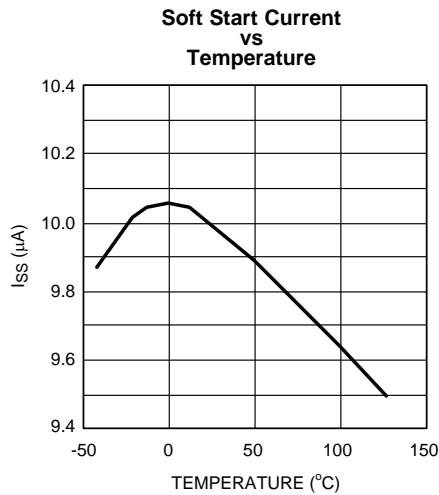

Figure 7.

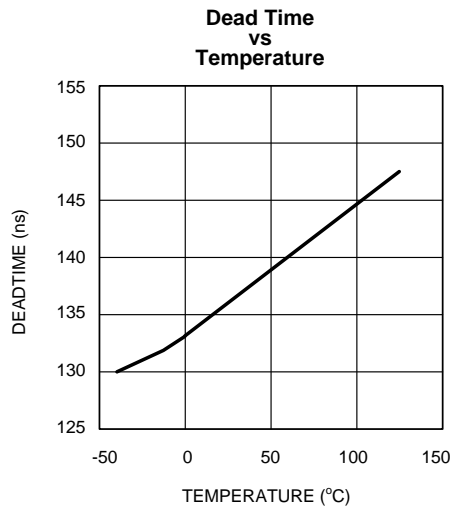

Figure 8.

Typical Performance Characteristics (continued)

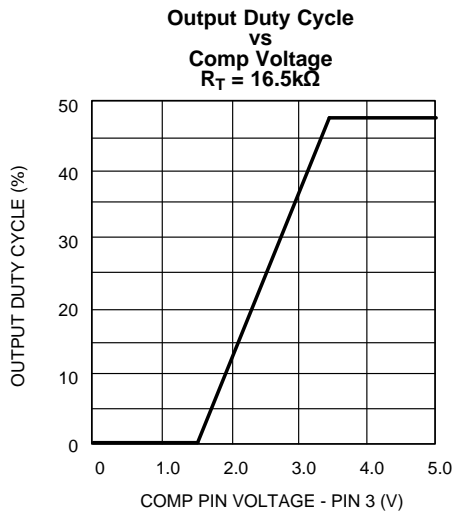

Figure 9.

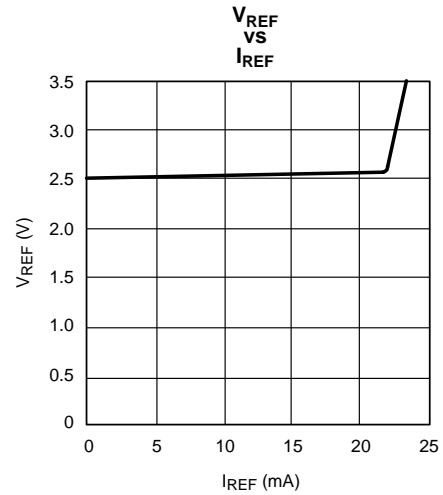

Figure 10.

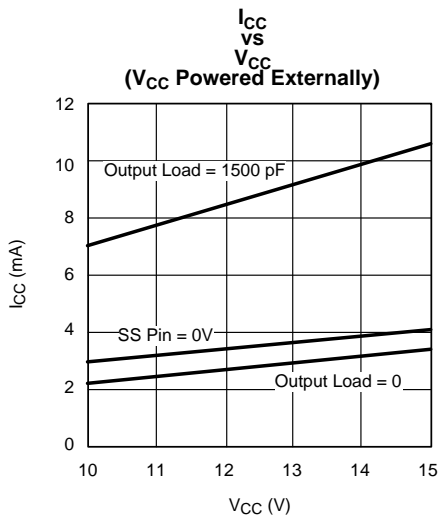

Figure 11.

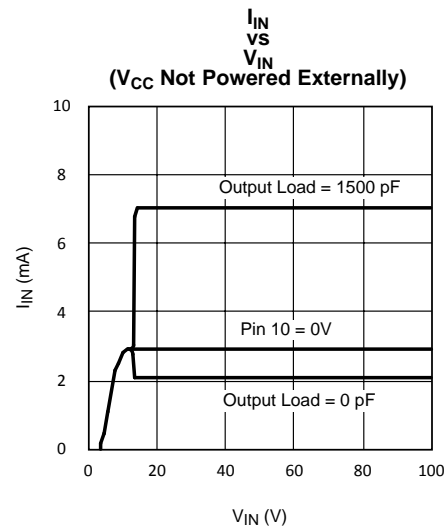

Figure 12.

## FUNCTIONAL DESCRIPTION

The LM5033 High Voltage PWM controller contains all of the features needed to implement Push-Pull and Bridge topologies, using voltage-mode control in a small 10 pin package. Features included are: startup regulator, precision 2.5V reference output, current limit detection, alternating gate drivers, sync capability, thermal shutdown, softstart, and remote shutdown. This high speed IC has total propagation delays <100 ns. These features simplify the design of an open loop DC-DC converter, or a voltage controlled closed loop converter. The Functional Block Diagram is shown in [Figure 2](#).

### High Voltage Start-Up Regulator (Pins 1, 4)

The LM5033 contains an internal high voltage startup regulator. The input pin ( $V_{IN}$ ) can be connected directly to line voltages as high as 90V for normal operation, and can withstand transients to 100V. The regulator output at  $V_{CC}$  (9.6V) is internally current limited and sources a minimum of 20mA. Upon power up, the capacitor at  $V_{CC}$  will charge up, providing a time delay while internal circuits stabilize. When  $V_{CC}$  reaches the upper threshold of the under-voltage sensor (typically 9.5V), the under-voltage sensor resets, enabling the output drivers, although the PWM duty cycle will initially be at zero. As the Softstart capacitor then charges up (described below) the output duty cycle will increase until regulated by the PWM control loop. The value of the  $V_{CC}$  capacitor which affects the above mentioned delay depends on the total system design and its start-up characteristics. The recommended range of values for the  $V_{CC}$  capacitor is 0.1 to 50 $\mu$ F.

The lower threshold of the under-voltage sensor is typically at 6.8V. If  $V_{CC}$  falls below this value the outputs are disabled and the softstart capacitor is discharged. When  $V_{CC}$  is again increased above the upper threshold the outputs are enabled, and the softstart sequence repeats.

The LM5033's internal power dissipation can be reduced by powering  $V_{CC}$  from an external supply. Typically this is done by means of an auxiliary transformer winding which is diode connected to the  $V_{CC}$  pin to provide 10-15V to  $V_{CC}$  as the controller completes the start-up sequence. The externally applied  $V_{CC}$  voltage will cause the internal regulator to shut off. The under-voltage sensor circuit will still function in this mode, requiring that the external  $V_{CC}$  capacitor be sized so that  $V_{CC}$  never falls below 6.8V. The required current into the  $V_{CC}$  pin from the external source is shown in [Typical Performance Characteristics](#) ( $I_{CC}$  vs.  $V_{CC}$ ).

If a fault condition occurs such that the external supply to  $V_{CC}$  fails, external current draw from the  $V_{CC}$  pin must be limited as to not exceed the regulator's current limit, or the maximum power dissipation of the IC. An external start-up or other bias rail can be used instead of the internal start-up regulator by connecting the  $V_{CC}$  and the  $V_{IN}$  pins together and feeding the external bias voltage (10-15V) into that node.

A thermal shutdown protection will activate if the die temperature exceeds 165°C, disabling the outputs (OUT1 and OUT2), and shutting down the  $V_{CC}$  regulator. When the die temperature has reduced below 150°C (typical hysteresis = 15°C) the  $V_{CC}$  regulator is enabled and a softstart sequence will initiate.

### Reference (Pin 2)

The Ref pin provides a reference voltage of 2.5V,  $\pm$ 2.4%. The pin is internally connected to an NMOS FET drain at the buffer amplifier's output, allowing it to sink, but not source current. An external pullup resistor is required. Current into the pin must be limited to less than 20 mA to maintain regulation. See the graph in the [Typical Performance Characteristics](#).

During start-up if the pullup voltage is present before the reference amplifier establishes regulation, the voltage on pin 2 must not exceed 5.5V. If this reference is not used the Ref pin can float or be connected to ground.

### PWM Comparator (Pin 3), Duty Cycle and Deadtime

The PWM comparator compares an internal ramp signal (0 - 0.65V) with the loop error voltage derived from the Comp pin (pin 3). The Comp voltage is typically set by an external error amplifier through an optocoupler for closed loop applications. Internally, the voltage at the Comp pin passes through two level shifting diodes, and a gain reducing 3:1 resistor divider. The output of the PWM comparator provides the pulse width information to the output drivers (Out1 and Out2). This comparator is optimized for speed in order to achieve minimum discernable duty cycles. The output duty cycle is 0% for  $V_{COMP} < 1.5V$ , and maximum for  $V_{COMP} > 3.5V$ . See the [Typical Performance Characteristics](#). The maximum duty cycle for each output is limited to less than 50% due to the forced deadtime. The typical deadtime between the falling edge of one gate driver output and the rising edge of the other gate driver output is 135 ns, and does not vary with frequency. The maximum duty cycle for each output can be calculated from:



$$DC = \frac{(0.5 \times T_S) - T_D}{T_S}$$

where

- $T_S$  is the period of each output
  - $T_D$  is the deadtime
- (1)

For example, if the oscillator frequency is 200 kHz, each output will cycle at 100 kHz, and  $T_S = 10 \mu\text{s}$ . Using the nominal deadtime of 135 ns, the maximum duty cycle at this frequency is 48.65%. Using the minimum deadtime of 85 ns, the maximum duty cycle increases to 49.15%.

When the Softstart pin (pin 10) is pulled down (internally or externally) the Comp pin voltage is pulled down with it, with a difference of 0.5V. When the Softstart pin voltage increases the Comp voltage is allowed to increase, pulled up by an internal 5.2V supply through a 5k $\Omega$  resistor.

In an open loop application, such as an intermediate bus converter, pin 3 can be left open resulting in maximum duty cycle at the output drivers .

### Current Sense (Pin 8)

The current sense circuit is intended to protect the power converter when an abnormal primary current is sensed by initiating a low duty cycle hiccup mode. When the threshold (0.5V) at Pin 8 is exceeded the outputs are disabled, and the softstart capacitor (at pin 10) is internally discharged. When the softstart capacitor is fully discharged **and** the voltage at the CS pin is below 0.5V, the outputs are re-enabled allowing the softstart capacitor voltage and the output duty cycle to increase.

The external current sensing circuit should include an RC filter located near the IC to prevent false triggering of the Current Sense comparator due to transients or noise. An internal MOSFET discharges the external filter capacitor at the conclusion of each PWM cycle to improve dynamic performance. The discharge time is equal to the deadtime between Out1 and Out2 at maximum duty cycle. Additionally, pin 8 is pulled low when  $V_{CC}$  is below the under-voltage threshold or when an over temperature condition occurs.

### Oscillator, Sync Capability (Pin 9)

The LM5033 oscillator frequency is set by a single external resistor connected between Rt/Sync and ground. The required Rt resistor is calculated from:

$$R_t = \frac{(1/F) - 172 \times 10^{-9}}{182 \times 10^{-12}}$$
(2)

The outputs (Out1 and Out2) alternate at half the oscillator frequency. The voltage at the Rt/Sync pin is internally regulated to a nominal 2.0V. The Rt resistor should be located as close as possible to the IC, and connected directly to the pins (Rt and GND).

The LM5033 can be synchronized to an external clock by applying a narrow pulse to pin 9. The external clock must be a higher frequency than the free running frequency set by the Rt resistor, and the pulse width must be between 15 and 150 ns. The clock signal must be coupled into the Rt/Sync pin through a 100 pF capacitor. When the synchronizing pulse transitions low-to-high, the voltage at pin 9 must exceed 3.8V from its nominal 2.0V dc level. During the clock signal's low time the voltage at pin 9 will be clamped at 2.0V by an internal regulator. The Rt resistor is always required, whether the oscillator is free running or externally synchronized.

### Soft Start (Pin 10)

The softstart feature allows the converter to gradually reach a steady state operating point, thereby reducing start-up stresses and current surges. Upon turn-on, after the under-voltage sensor resets at  $V_{CC}$ , an internal 10  $\mu\text{A}$  current source charges an external capacitor at pin 10 to generate a ramping voltage (0 to + 5V) which allows the voltage on the Comp pin (pin 3) to increase gradually. As the COMP voltage increases the output duty cycle will increase from zero to the value required for regulation. Internally, the softstart pin is pulled low when a current fault is detected at pin 8, the  $V_{CC}$  voltage is below the lower threshold of the under-voltage sensor, or when a thermal shutdown occurs. Additionally, the softstart pin can be pulled low by an external device.

In the event of a current fault, (see [Current Sense](#) section) the softstart capacitor will be discharged by an internal pull-down device. The falling voltage at pin 10 will pull down the COMP pin, thereby ensuring a minimum output duty cycle when the outputs are re-enabled. The softstart capacitor will then begin to ramp up, allowing the COMP voltage to increase. As the COMP voltage increases, the output duty cycle increases from zero to the value required for regulation. However, if the fault condition is still present the above sequence repeats until the fault is removed.

If the  $V_{CC}$  voltage falls below the lower under-voltage sensor threshold (typically 6.8V) the outputs are disabled, and the softstart capacitor is discharged. The falling voltage at pin 10 will pull down the COMP pin, thereby ensuring minimum output duty cycle when the outputs are re-enabled. After the  $V_{CC}$  voltage increases above the upper threshold (typically 9.5V), the outputs are enabled, and the softstart capacitor will begin to ramp up, allowing the COMP pin voltage to increase. The output duty cycle will then increase from zero to the value required for regulation.

In the event of a fault which results in an excessively high die temperature, an internal Thermal Shutdown circuit is provided to protect the IC. When activated (at 165°C) the IC is forced into a low power reset state, disabling the output drivers and the  $V_{CC}$  regulator. When the die temperature has reduced (typical hysteresis = 15°C), the  $V_{CC}$  regulator is enabled and a softstart sequence will initiate.

Using an externally controlled switch, the outputs (Pins 5 & 6) can be disabled at any time by pulling pin 10 below 0.5V. This will pull down the COMP pin to near ground, causing the output duty cycle to go to zero. Upon releasing pin 10, the softstart capacitor will ramp up, allowing the COMP pin voltage to increase. The output duty cycle then increases from zero to the value required for regulation.

### OUT1, OUT2 (Pins 5, 6)

The LM5033 provides two alternating outputs, OUT1 and OUT2, each capable of sourcing and sinking 1.5A peak. Each will toggle at one-half the internal oscillator frequency. The voltage output levels are nominally ground and  $V_{CC}$ , minus a saturation voltage at each level which depends on the current flow.

The outputs can drive power MOSFETs directly in a push-pull application, or they can drive a high voltage gate driver (e.g., LM5100) in a bridge application.

The outputs are disabled when any of the following conditions occur:

1. An overcurrent condition is detected at pin 8,
2. The  $V_{CC}$  under-voltage sensor is active,
3. An over-temperature condition is detected, or
4. The voltage at Pin 10 is below 0.5V

### Thermal Protection

The system design should limit the LM5033 junction temperature to not exceed 125°C during normal operation. However, in the event of a fault which results in a higher die temperature, an internal Thermal Shutdown circuit is provided to protect the IC. When thermal shutdown is activated, typically at 165°C, the IC is forced into a low power reset state disabling the output drivers and the  $V_{CC}$  regulator. This feature helps prevent catastrophic failures from accidental device overheating. When the die temperature has reduced (typical hysteresis = 15°C) the  $V_{CC}$  regulator is enabled and a softstart sequence initiates.

### Application Information

The following information is intended to provide guidelines for implementing the LM5033. However, final selection of all external components is dependent on the configuration and operating characteristics of the complete power conversion system.

#### $V_{IN}$ (PIN 1)

The voltage applied at pin 1, normally the same as that applied to the main transformer's primary, can be in the range of 15 to 90V, with transient capability to 100V. The current into pin 1 depends not only on  $V_{IN}$ , but also on the load on the output driver pins, any load on  $V_{CC}$ , and whether or not an external voltage is applied to  $V_{CC}$ . If  $V_{in}$  is close to the absolute maximum rating of the LM5033, it is recommended the circuit of [Figure 13](#) be used to filter transients which may occur at the input supply.

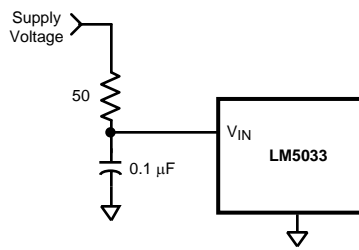

**Figure 13. Input Transient Protection**

If  $V_{CC}$  is not powered externally, requiring all internal bias currents for the LM5033, and output driver currents, to be supplied at  $V_{IN}$  and through the internal regulator, the required input current ( $I_{IN}$ ) is shown in the Typical Performance Characteristics ( $I_{IN}$  vs.  $V_{IN}$ ).

If  $V_{CC}$  is powered externally,  $I_{IN}$  will increase with  $V_{IN}$  as shown in the above mentioned graph until the external voltage is applied to  $V_{CC}$ . In most applications, this occurs once the outputs are enabled and load current begins to flow. The current into  $V_{IN}$  will then drop to a nominal 150 $\mu$ A (Pin 10 = open or grounded).

#### **$V_{CC}$ (PIN 4)**

The capacitor at the  $V_{CC}$  pin provides not only noise filtering and stability, but also a necessary time delay during start-up. The time delay allows the internal circuitry of the LM5033, and associated external circuitry, to stabilize before  $V_{CC}$  reaches its final value, at which time the outputs are enabled and the softstart sequence begins. Any external circuitry connected to the REF output (Pin 2) and Softstart (Pin 10) should be designed to stabilize during the time delay.

The current limit of the  $V_{CC}$  regulator, and the external capacitor, determine the  $V_{CC}$  turn-on time delay. Typically, a 1 $\mu$ F capacitor will provide approximately 300  $\mu$ s of delay, with larger capacitors providing proportionately longer delays. Experimentation with the final design may be necessary to determine the minimum value for the  $V_{CC}$  capacitor.

#### **SOFTSTART (PIN 10)**

The capacitor at pin 10 determines the time required for the output duty cycle to increase from zero to the final value for regulation. The minimum acceptable time is dependent on the response of the feedback loops to the COMP pin, as well as the characteristics of the magnetic components. If the Softstart time is too quick, the system output could significantly overshoot its intended voltage before the loop has a chance to establish regulation, possibly adversely affecting the load. Experimentation with the final design is usually necessary to determine the minimum value for the SS capacitor.

#### **CURRENT SENSE (PIN 8)**

This pin typically receives an input representative of the primary current from the current sense elements of the external circuitry. The peak amplitude at this pin must be less than 0.5V for normal operation. Filtering at this pin should be sufficient to prevent false triggering of the Current Sense comparator, but not significantly delay detection of an overcurrent condition. The filter's capacitor at pin 8 should not be larger than 2200 pF.

#### **OSCILLATOR, SYNC INPUT (PIN 9)**

The internal oscillator frequency is generally selected in conjunction with the system magnetic components, and any other aspects of the system which may be affected by the frequency. The  $R_t$  resistor at pin 9 sets the frequency according to the formula in the Functional Description. Each output (OUT1 and OUT2) switches at half the oscillator frequency. If the required frequency value is critical in a particular application, the tolerance of the external resistor, and the frequency tolerance indicated in the Electrical Characteristics, must be taken into account when selecting the resistor.

If the LM5033 is to be synchronized to an external clock, that signal must be coupled into pin 9 through a 100 pF capacitor. The  $R_t$  resistor is still required in this case, and it must be selected to set the internal oscillator to a frequency lower than the external synchronizing frequency. The amplitude of the external pulses must take pin 9 above 3.8V on the low-to-high transition but no higher than 5.5V. The clock pulse width should be between 15 and 150 ns.

## DEADTIME ADJUSTMENT

If the application requires a change in the minimum deadtime between the outputs, the circuits in Figure 14 are recommended. Suggested values for the resistor and capacitor at each output are 500Ω, and 100 pF, respectively for a nominal 50 ns change. The diodes can be 1N4148, or similar.

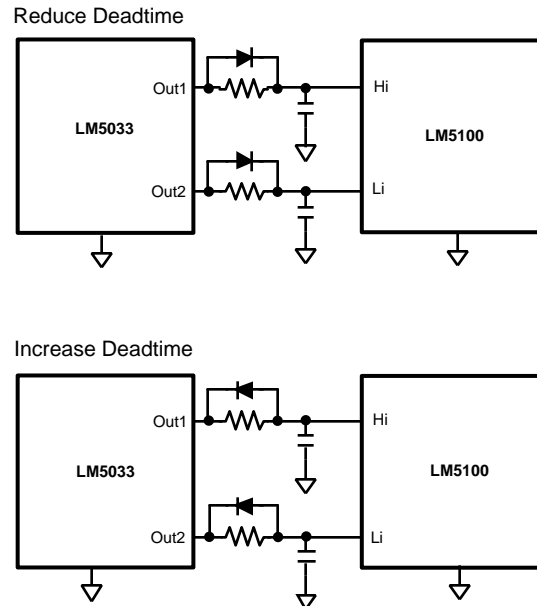

**Figure 14. Deadtime Adjustment**

## PC BOARD LAYOUT

The LM5033 current sense and PWM comparators are very fast, and as such will respond to short duration noise pulses. Layout considerations are critical for the current sense filter. The components at pins 3, 8, 9, and 10 should be as physically close as possible to the IC, thereby minimizing noise pickup in the PC tracks.

If a current sense transformer is used both leads of the transformer secondary should be routed to the sense filter components, and to the IC pins. The ground side of the transformer should be connected via a dedicated PC board track to pin 7 of the IC rather than through the ground plane.

If the current sense circuit employs a sense resistor in the drive transistor sources, a low inductance resistor should be used. In this case all the noise sensitive low power grounds should be connected in common near the IC, and then a single connection made to the power ground (sense resistor ground point).

The outputs of the LM5033, or of the high voltage gate driver (if used), should have short direct paths to the power MOSFETs in order to minimize the effects of inductance in the PC board traces.

If the internal dissipation of the LM5033 and any of the power devices produces high junction temperatures during normal operation, good use of the PC board's ground plane can help considerably to dissipate heat. The exposed pad on the bottom of the WSON-10 package can be soldered to ground plane on the PC board, and the ground plane should extend out from beneath the IC to help dissipate the heat. The exposed pad is internally connected to the IC substrate.

Additionally, the use of wide PC board traces where possible can help conduct heat away from the IC. Judicious positioning of the PC board within the end product, along with use of any available air flow (forced or natural convection) can help reduce the junction temperatures.

**APPLICATION CIRCUIT EXAMPLE**

Figure 17 shows an example circuit for a half-bridge 200W DC/DC converter built in a quarter brick format. The circuit is that of an intermediate bus converter (IBC) which operates open-loop (unregulated output), converting a nominal 48V input to a nominal 9.0V output with a 30 mΩ output impedance. The current sense transformer (T2), and the associated filter at the CS pin, provide overcurrent detection at approximately 23A. The auxiliary winding on T1 powers V<sub>CC</sub> and the LM5100's V+ pin (once the outputs are enabled) to reduce power dissipation within the LM5033. The LM5100 provides appropriate level shifting for Q1. Synchronous rectifiers Q3 and Q4 minimize conduction losses in the output stage. Dual comparators U2 and U3 provide under-voltage and over-voltage sensing at V<sub>in</sub>. The under-voltage sense levels are 37V increasing, and 33V decreasing. The over-voltage sense levels are 63V increasing, and 61.5V decreasing. The circuit can be shut down by taking the ON/OFF input below 0.8V. An external synchronizing frequency can be applied to the SYNC input. Measured efficiency and output characteristics for this circuit are shown in Figure 15 and Figure 16.

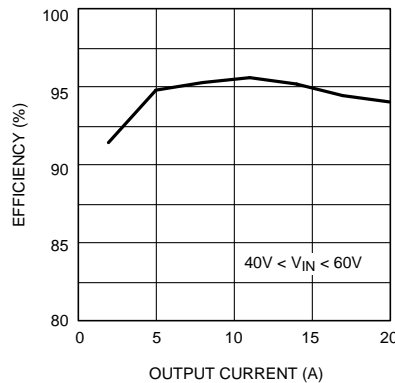

**Figure 15. Efficiency vs Output Current Circuit of Figure 17**

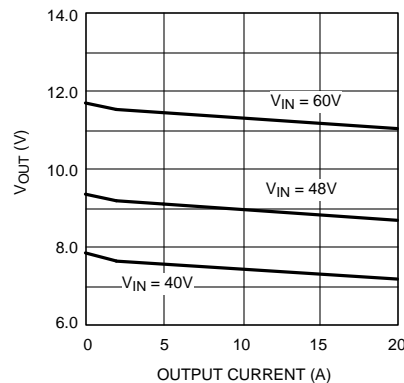

**Figure 16. V<sub>OUT</sub> vs Load Current and V<sub>IN</sub> for the circuit of Figure 17**

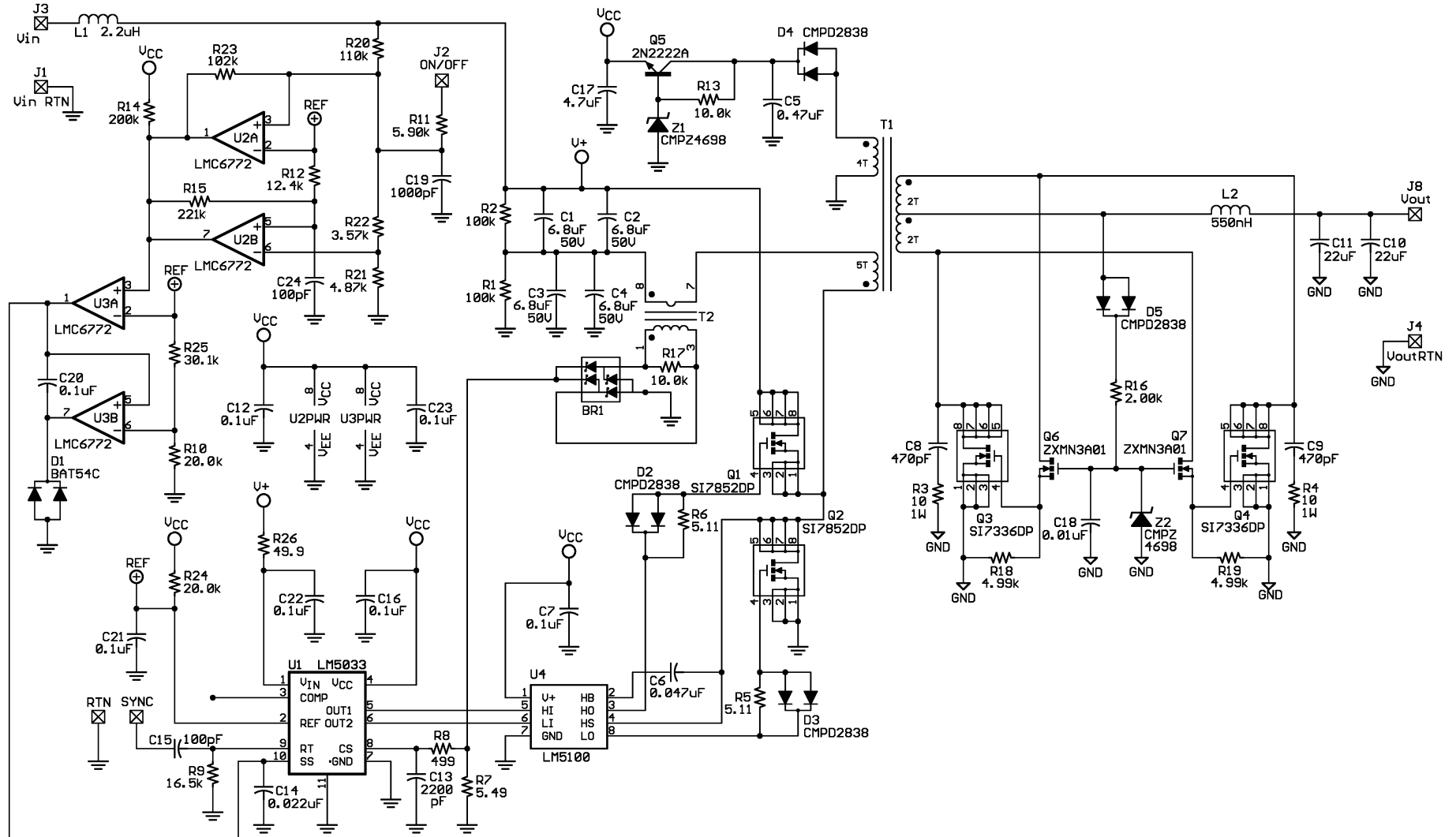

Figure 17. Intermediate Bus Converter  
40V - 60V Input; 7.5 - 11.3V, 20A Output

**Table 1. Bill of Materials (for the circuit of [Figure 17](#))**

Item	Device	Package	Value
BR1	Schottky diode bridge, Diodes, Inc. BAT54BRW	SOT-363	30V, 0.2A
C1-4	Capacitor	1812	6.8 $\mu$ F, 50V
C5	Capacitor	0805	0.47 $\mu$ F, 25V
C6	Capacitor	0805	0.047 $\mu$ F, 25V
C7, 12, 16, 20-23	Capacitor	0805	0.1 $\mu$ F, 16V
C8, 9	Capacitor	0805	470 pF, 50V
C10, 11	Capacitor	1210	22 $\mu$ F, 16 V
C13	Capacitor	0805	2200 pF, 16V
C14	Capacitor	0805	0.022 $\mu$ F, 16V
C15, 24	Capacitor	0805	100 pF, 16V
C17	Capacitor	1206	4.7 $\mu$ F, 16V
C18	Capacitor	0805	0.01 $\mu$ F, 16V
C19	Capacitor	0805	1000 pF, 16V
D1	Dual Schottky diode, Vishay BAT54C	SOT-23	30V, 0.2A
D2-5	Dual diode, Central Semi CMPD2838	SOT-23	75V, 0.2A
L1	Inductor, TDK RLF7030T-2R2M5R4	SMD	2.2 $\mu$ H, 5.5A
L2	Inductor, TDK SPM12535T- R60M220	SMD	550 nH, 22A
Q1, 2	N Channel MOSFET, Vishay Si7852DP	PowerPAK SO-8	80V, 12.5A
Q3, 4	N Channel MOSFET, Vishay Si7336DP	PowerPAK SO-8	30V, 30A
Q5	NPN 2N2222A Transistor	SOT-23	75V, 0.6A
Q6, 7	N Channel MOSFET, Zetex ZXMN3A01	SOT-23	30V, 2 A
R1, 2	Resistor	1206	100 k $\Omega$ , 1/4W
R3, 4	Resistor	2512	10 $\Omega$ , 1W
R5, 6	Resistor	0805	5.11 $\Omega$
R7	Resistor	0805	5.49 $\Omega$
R8	Resistor	0805	499 $\Omega$
R9	Resistor	0805	16.5 k $\Omega$
R10, 24	Resistor	0805	20 k $\Omega$
R11	Resistor	0805	5.9 k $\Omega$
R12	Resistor	0805	12.4 k $\Omega$
R13, 17	Resistor	0805	10 k $\Omega$
R14	Resistor	0805	200 k $\Omega$
R15	Resistor	0805	221 k $\Omega$
R16	Resistor	0805	2.0 k $\Omega$
R18, 19	Resistor	0805	4.99 k $\Omega$
R20	Resistor	1206	110 k $\Omega$ , 1W
R21	Resistor	0805	4.87 k $\Omega$
R22	Resistor	0805	3.57 k $\Omega$
R23	Resistor	0805	102 k $\Omega$
R25	Resistor	0805	30.1 k $\Omega$
R26	Resistor	0805	49.9 $\Omega$
T1	Power Transformer, Coilcraft B0853-A	Planar	

**Table 1. Bill of Materials (for the circuit of Figure 17) (continued)**

Item	Device	Package	Value
T2	Current sense transformer, Pulse Eng. P8208	SMD	100:1, 10A
U1	PWM Controller, TI LM5033D	WSO-10	
U2, 3	Dual Micropower Comparator, TI LMC6772	VSSOP	
U4	Gate driver, TI LM5100M	SOIC	
Z1, 2	Zener diode, Central Semi CMPZ4698	SOT-23	11V, 350 mW



---

**REVISION HISTORY**

<b>Changes from Revision A (April 2013) to Revision B</b>	<b>Page</b>
<hr/> <ul style="list-style-type: none"><li>• Changed layout of National Data Sheet to TI format .....</li></ul>	<hr/> <a href="#">15</a>

**PACKAGING INFORMATION**

Orderable Device	Status (1)	Package Type	Package Drawing	Pins	Package Qty	Eco Plan (2)	Lead/Ball Finish	MSL Peak Temp (3)	Op Temp (°C)	Device Marking (4/5)	Samples
LM5033MM/NOPB	ACTIVE	VSSOP	DGS	10	1000	Green (RoHS & no Sb/Br)	CU SN	Level-1-260C-UNLIM	-40 to 125	SCVB	<a href="#">Samples</a>
LM5033MMX/NOPB	ACTIVE	VSSOP	DGS	10	3500	Green (RoHS & no Sb/Br)	CU SN	Level-1-260C-UNLIM	-40 to 125	SCVB	<a href="#">Samples</a>
LM5033SD/NOPB	ACTIVE	WSON	DPR	10	1000	Green (RoHS & no Sb/Br)	SN	Level-1-260C-UNLIM	-40 to 125	5033SD	<a href="#">Samples</a>
LM5033SDX/NOPB	ACTIVE	WSON	DPR	10	4500	Green (RoHS & no Sb/Br)	SN	Level-1-260C-UNLIM	-40 to 125	5033SD	<a href="#">Samples</a>

(1) The marketing status values are defined as follows:

**ACTIVE:** Product device recommended for new designs.

**LIFEBUY:** TI has announced that the device will be discontinued, and a lifetime-buy period is in effect.

**NRND:** Not recommended for new designs. Device is in production to support existing customers, but TI does not recommend using this part in a new design.

**PREVIEW:** Device has been announced but is not in production. Samples may or may not be available.

**OBSOLETE:** TI has discontinued the production of the device.

(2) Eco Plan - The planned eco-friendly classification: Pb-Free (RoHS), Pb-Free (RoHS Exempt), or Green (RoHS & no Sb/Br) - please check <http://www.ti.com/productcontent> for the latest availability information and additional product content details.

**TBD:** The Pb-Free/Green conversion plan has not been defined.

**Pb-Free (RoHS):** TI's terms "Lead-Free" or "Pb-Free" mean semiconductor products that are compatible with the current RoHS requirements for all 6 substances, including the requirement that lead not exceed 0.1% by weight in homogeneous materials. Where designed to be soldered at high temperatures, TI Pb-Free products are suitable for use in specified lead-free processes.

**Pb-Free (RoHS Exempt):** This component has a RoHS exemption for either 1) lead-based flip-chip solder bumps used between the die and package, or 2) lead-based die adhesive used between the die and leadframe. The component is otherwise considered Pb-Free (RoHS compatible) as defined above.

**Green (RoHS & no Sb/Br):** TI defines "Green" to mean Pb-Free (RoHS compatible), and free of Bromine (Br) and Antimony (Sb) based flame retardants (Br or Sb do not exceed 0.1% by weight in homogeneous material)

(3) MSL, Peak Temp. -- The Moisture Sensitivity Level rating according to the JEDEC industry standard classifications, and peak solder temperature.

(4) There may be additional marking, which relates to the logo, the lot trace code information, or the environmental category on the device.

(5) Multiple Device Markings will be inside parentheses. Only one Device Marking contained in parentheses and separated by a "~" will appear on a device. If a line is indented then it is a continuation of the previous line and the two combined represent the entire Device Marking for that device.

**Important Information and Disclaimer:** The information provided on this page represents TI's knowledge and belief as of the date that it is provided. TI bases its knowledge and belief on information provided by third parties, and makes no representation or warranty as to the accuracy of such information. Efforts are underway to better integrate information from third parties. TI has taken and

continues to take reasonable steps to provide representative and accurate information but may not have conducted destructive testing or chemical analysis on incoming materials and chemicals. TI and TI suppliers consider certain information to be proprietary, and thus CAS numbers and other limited information may not be available for release.

In no event shall TI's liability arising out of such information exceed the total purchase price of the TI part(s) at issue in this document sold by TI to Customer on an annual basis.

**TAPE AND REEL INFORMATION**

**QUADRANT ASSIGNMENTS FOR PIN 1 ORIENTATION IN TAPE**

\*All dimensions are nominal

Device	Package Type	Package Drawing	Pins	SPQ	Reel Diameter (mm)	Reel Width W1 (mm)	A0 (mm)	B0 (mm)	K0 (mm)	P1 (mm)	W (mm)	Pin1 Quadrant
LM5033MM/NOPB	VSSOP	DGS	10	1000	178.0	12.4	5.3	3.4	1.4	8.0	12.0	Q1
LM5033MMX/NOPB	VSSOP	DGS	10	3500	330.0	12.4	5.3	3.4	1.4	8.0	12.0	Q1
LM5033SD/NOPB	WSOP	DPR	10	1000	178.0	12.4	4.3	4.3	1.3	8.0	12.0	Q1
LM5033SDX/NOPB	WSOP	DPR	10	4500	330.0	12.4	4.3	4.3	1.3	8.0	12.0	Q1

**TAPE AND REEL BOX DIMENSIONS**

\*All dimensions are nominal

Device	Package Type	Package Drawing	Pins	SPQ	Length (mm)	Width (mm)	Height (mm)
LM5033MM/NOPB	VSSOP	DGS	10	1000	203.0	190.0	41.0
LM5033MMX/NOPB	VSSOP	DGS	10	3500	367.0	367.0	35.0
LM5033SD/NOPB	WSON	DPR	10	1000	203.0	190.0	41.0
LM5033SDX/NOPB	WSON	DPR	10	4500	367.0	367.0	35.0

DGS (S-PDSO-G10)

PLASTIC SMALL-OUTLINE PACKAGE

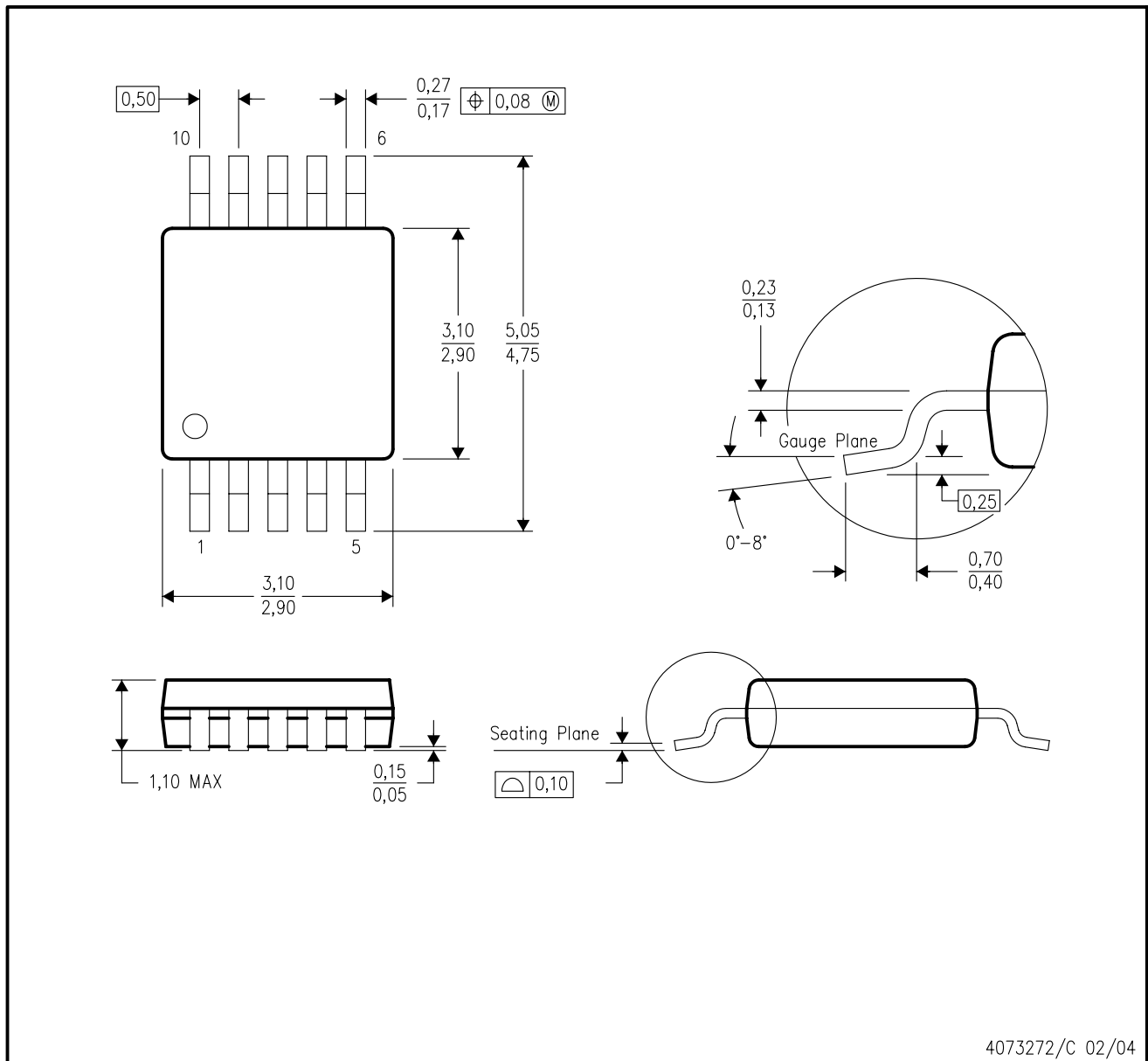

- NOTES:
- A. All linear dimensions are in millimeters.
  - B. This drawing is subject to change without notice.
  - C. Body dimensions do not include mold flash or protrusion.
  - D. Falls within JEDEC MO-187 variation BA.

DPR0010A

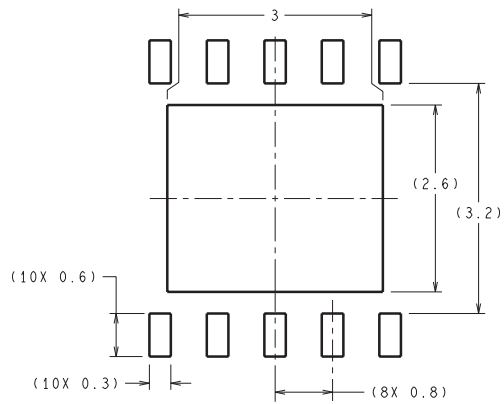

RECOMMENDED LAND PATTERN

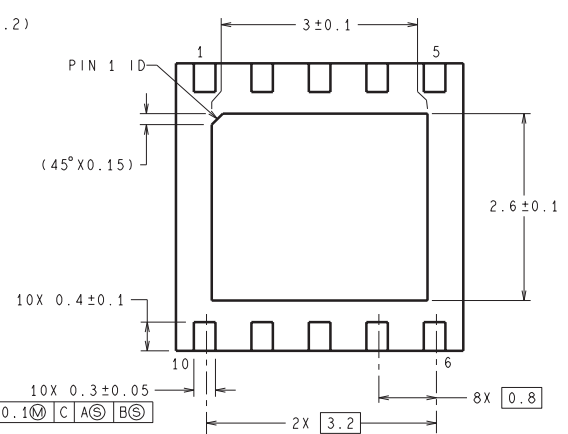
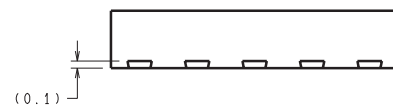
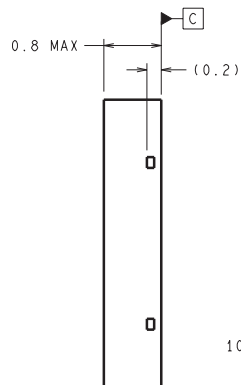
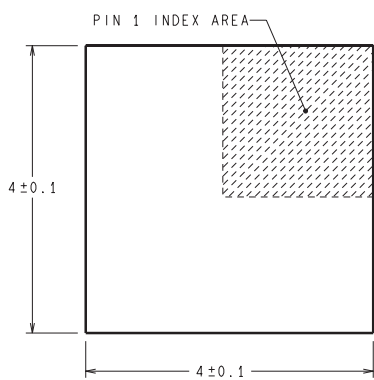

DIMENSIONS ARE IN MILLIMETERS

SDC10A (Rev A)

## IMPORTANT NOTICE

Texas Instruments Incorporated and its subsidiaries (TI) reserve the right to make corrections, enhancements, improvements and other changes to its semiconductor products and services per JESD46, latest issue, and to discontinue any product or service per JESD48, latest issue. Buyers should obtain the latest relevant information before placing orders and should verify that such information is current and complete. All semiconductor products (also referred to herein as "components") are sold subject to TI's terms and conditions of sale supplied at the time of order acknowledgment.

TI warrants performance of its components to the specifications applicable at the time of sale, in accordance with the warranty in TI's terms and conditions of sale of semiconductor products. Testing and other quality control techniques are used to the extent TI deems necessary to support this warranty. Except where mandated by applicable law, testing of all parameters of each component is not necessarily performed.

TI assumes no liability for applications assistance or the design of Buyers' products. Buyers are responsible for their products and applications using TI components. To minimize the risks associated with Buyers' products and applications, Buyers should provide adequate design and operating safeguards.

TI does not warrant or represent that any license, either express or implied, is granted under any patent right, copyright, mask work right, or other intellectual property right relating to any combination, machine, or process in which TI components or services are used. Information published by TI regarding third-party products or services does not constitute a license to use such products or services or a warranty or endorsement thereof. Use of such information may require a license from a third party under the patents or other intellectual property of the third party, or a license from TI under the patents or other intellectual property of TI.

Reproduction of significant portions of TI information in TI data books or data sheets is permissible only if reproduction is without alteration and is accompanied by all associated warranties, conditions, limitations, and notices. TI is not responsible or liable for such altered documentation. Information of third parties may be subject to additional restrictions.

Resale of TI components or services with statements different from or beyond the parameters stated by TI for that component or service voids all express and any implied warranties for the associated TI component or service and is an unfair and deceptive business practice. TI is not responsible or liable for any such statements.

Buyer acknowledges and agrees that it is solely responsible for compliance with all legal, regulatory and safety-related requirements concerning its products, and any use of TI components in its applications, notwithstanding any applications-related information or support that may be provided by TI. Buyer represents and agrees that it has all the necessary expertise to create and implement safeguards which anticipate dangerous consequences of failures, monitor failures and their consequences, lessen the likelihood of failures that might cause harm and take appropriate remedial actions. Buyer will fully indemnify TI and its representatives against any damages arising out of the use of any TI components in safety-critical applications.

In some cases, TI components may be promoted specifically to facilitate safety-related applications. With such components, TI's goal is to help enable customers to design and create their own end-product solutions that meet applicable functional safety standards and requirements. Nonetheless, such components are subject to these terms.

No TI components are authorized for use in FDA Class III (or similar life-critical medical equipment) unless authorized officers of the parties have executed a special agreement specifically governing such use.

Only those TI components which TI has specifically designated as military grade or "enhanced plastic" are designed and intended for use in military/aerospace applications or environments. Buyer acknowledges and agrees that any military or aerospace use of TI components which have **not** been so designated is solely at the Buyer's risk, and that Buyer is solely responsible for compliance with all legal and regulatory requirements in connection with such use.

TI has specifically designated certain components as meeting ISO/TS16949 requirements, mainly for automotive use. In any case of use of non-designated products, TI will not be responsible for any failure to meet ISO/TS16949.

### Products

Audio	<a href="http://www.ti.com/audio">www.ti.com/audio</a>
Amplifiers	<a href="http://amplifier.ti.com">amplifier.ti.com</a>
Data Converters	<a href="http://dataconverter.ti.com">dataconverter.ti.com</a>
DLP® Products	<a href="http://www.dlp.com">www.dlp.com</a>
DSP	<a href="http://dsp.ti.com">dsp.ti.com</a>
Clocks and Timers	<a href="http://www.ti.com/clocks">www.ti.com/clocks</a>
Interface	<a href="http://interface.ti.com">interface.ti.com</a>
Logic	<a href="http://logic.ti.com">logic.ti.com</a>
Power Mgmt	<a href="http://power.ti.com">power.ti.com</a>
Microcontrollers	<a href="http://microcontroller.ti.com">microcontroller.ti.com</a>
RFID	<a href="http://www.ti-rfid.com">www.ti-rfid.com</a>
OMAP Applications Processors	<a href="http://www.ti.com/omap">www.ti.com/omap</a>
Wireless Connectivity	<a href="http://www.ti.com/wirelessconnectivity">www.ti.com/wirelessconnectivity</a>

### Applications

Automotive and Transportation	<a href="http://www.ti.com/automotive">www.ti.com/automotive</a>
Communications and Telecom	<a href="http://www.ti.com/communications">www.ti.com/communications</a>
Computers and Peripherals	<a href="http://www.ti.com/computers">www.ti.com/computers</a>
Consumer Electronics	<a href="http://www.ti.com/consumer-apps">www.ti.com/consumer-apps</a>
Energy and Lighting	<a href="http://www.ti.com/energy">www.ti.com/energy</a>
Industrial	<a href="http://www.ti.com/industrial">www.ti.com/industrial</a>
Medical	<a href="http://www.ti.com/medical">www.ti.com/medical</a>
Security	<a href="http://www.ti.com/security">www.ti.com/security</a>
Space, Avionics and Defense	<a href="http://www.ti.com/space-avionics-defense">www.ti.com/space-avionics-defense</a>
Video and Imaging	<a href="http://www.ti.com/video">www.ti.com/video</a>

### TI E2E Community

[e2e.ti.com](http://e2e.ti.com)