

FULL DIFFERENTIAL ANALOG INPUT 24-BIT, 192-kHz STEREO A/D CONVERTER

Check for Samples: [PCM1804-Q1](#)

FEATURES

- Qualified for Automotive Applications
- AEC-Q100 Test Guidance With the Following Results:
 - Device Temperature Grade 3: –40°C to 85°C Ambient Operating Temperature Range
 - Device HBM ESD Classification Level H2
 - Device CDM ESD Classification Level C3B
- 24-Bit Delta-Sigma Stereo A/D Converter
- High Performance:
 - Dynamic Range: 112 dB (Typical)
 - SNR: 111 dB (Typical)
 - THD+N: –102 dB (Typical)
- High-Performance Linear Phase Antialias Digital Filter:
 - Pass-Band Ripple: ±0.005 dB
 - Stop-Band Attenuation: –100 dB
- Fully Differential Analog Input: ±2.5 V
- Audio Interface: Master- or Slave-Mode Selectable
- Data Formats: Left-Justified, I²S, Standard 24-Bit, and DSD
- Function:
 - Peak Detection
 - High-Pass Filter (HPF): –3 dB at 1 Hz, $f_s = 48$ kHz
- Sampling Rate up to 192 kHz
- System Clock: 128 f_s , 256 f_s , 384 f_s , 512 f_s , or 768 f_s

- Dual Power Supplies:
 - 5 V for Analog
 - 3.3 V for Digital
- Power Dissipation: 225 mW
- Small 28-Pin SSOP
- DSD Output: 1 Bit, 64 f_s

APPLICATIONS

- AV Amplifier
- MD Player
- Digital VTR
- Digital Mixer
- Digital Recorder

DESCRIPTION

The PCM1804-Q1 device is a high-performance, single-chip stereo A/D converter with fully differential analog voltage input which uses a precision delta-sigma modulator and includes a linear-phase antialias digital filter and high-pass filter (HPF) that removes DC offset from the input signal. The PCM1804-Q1 device is suitable for a wide variety of mid- to high-grade consumer and professional applications, where excellent performance and 5-V analog supply and 3.3-V digital power-supply operation are required. The PCM1804-Q1 device can achieve both PCM audio and DSD format due to the precision delta-sigma modulator. The PCM1804-Q1 device is fabricated using an advanced CMOS process and is available in a small 28-pin SSOP package.



Please be aware that an important notice concerning availability, standard warranty, and use in critical applications of Texas Instruments semiconductor products and disclaimers thereto appears at the end of this data sheet.

System Two, Audio Precision are trademarks of Audio Precision, Inc.
All other trademarks are the property of their respective owners.



This integrated circuit can be damaged by ESD. Texas Instruments recommends that all integrated circuits be handled with appropriate precautions. Failure to observe proper handling and installation procedures can cause damage.

ESD damage can range from subtle performance degradation to complete device failure. Precision integrated circuits may be more susceptible to damage because very small parametric changes could cause the device not to meet its published specifications.

ORDERING INFORMATION

T _A	PACKAGE	ORDERABLE PART NUMBER	TOP-SIDE MARKING
-40°C to 85°C	SSOP - DB Reel of 2000	PCM1804S1IDBRQ1	PCM1804Q

FUNCTIONAL BLOCK DIAGRAM

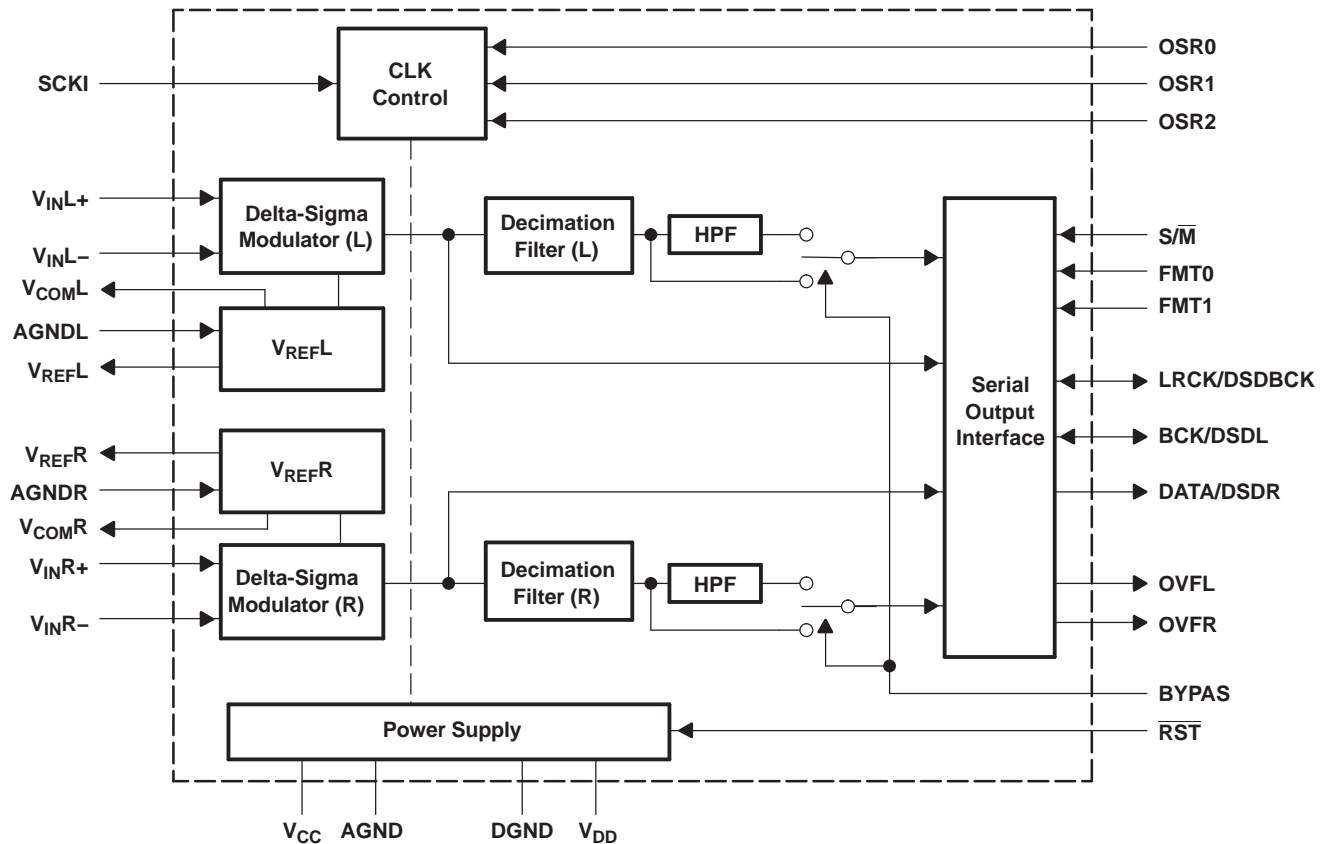

B0029-01

PIN ASSIGNMENTS

PCM1804 PACKAGE
(TOP VIEW)

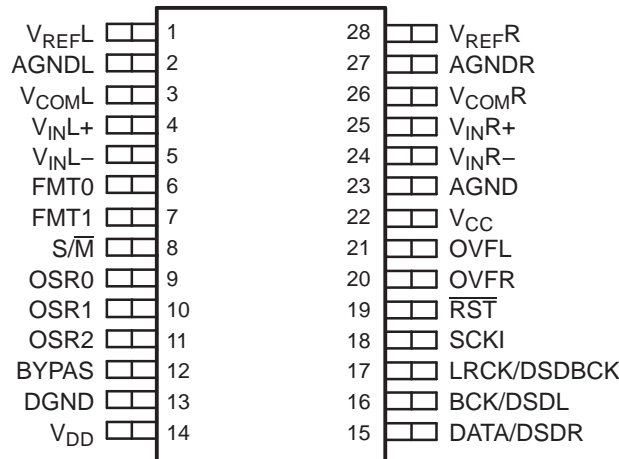

P0007-02

Pin Functions

NAME	PIN	I/O	DESCRIPTIONS
AGND	23	–	Analog ground
AGNDL	2	–	Analog ground for V_{REFL}
AGNDR	27	–	Analog ground for V_{REFR}
BCK/DSDL	16	I/O	Bit clock input/output in PCM mode. Left-channel audio data output in DSD mode. ⁽¹⁾
BYPAS	12	I	HPF bypass control. High: HPF disabled. Low: HPF enabled. ⁽¹⁾
DATA/DSDR	15	O	Left-channel and right-channel audio data output in PCM mode. Right-channel audio data output in DSD mode. (DSD output, when in DSD mode)
DGND	13	–	Digital ground
FMT0	6	I	Audio data format 0. See Table 5 . ⁽²⁾
FMT1	7	I	Audio data format 1. See Table 5 . ⁽²⁾
LRCK/DSDBCK	17	I/O	Sampling clock input/output in PCM and DSD modes. ⁽¹⁾
OSR0	9	I	Oversampling ratio 0. See Table 1 and Table 2 . ⁽²⁾
OSR1	10	I	Oversampling ratio 1. See Table 1 and Table 2 . ⁽²⁾
OSR2	11	I	Oversampling ratio 2. See Table 1 and Table 2 . ⁽²⁾
OVFL	21	O	Overflow signal of left-channel in PCM mode. This is available in PCM mode only.
OVFR	20	O	Overflow signal of right-channel in PCM mode. This is available in PCM mode only.
\overline{RST}	19	I	Reset, power-down input, active-low ⁽²⁾
SCKI	18	I	System clock input; 128 f_S , 256 f_S , 384 f_S , 512 f_S , or 768 f_S . ⁽³⁾
S/M	8	I	Slave or master mode selection. See Table 4 . ⁽²⁾
V_{CC}	22	–	Analog power supply
V_{COML}	3	–	Left-channel analog common-mode voltage (2.5 V)
V_{COMR}	26	–	Right-channel analog common-mode voltage (2.5 V)
V_{DD}	14	–	Digital power supply
V_{INL-}	5	I	Left-channel analog input, negative pin
V_{INL+}	4	I	Left-channel analog input, positive pin
V_{INR-}	24	I	Right-channel analog input, negative pin

(1) Schmitt-trigger input

(2) Schmitt-trigger input with internal pulldown (51 k Ω typically), 5-V tolerant.

(3) Schmitt-trigger input, 5-V tolerant.

Pin Functions (continued)

NAME	PIN	I/O	DESCRIPTIONS
V _{INR+}	25	I	Right-channel analog input, positive pin
V _{REFL}	1	–	Left-channel voltage reference output, requires capacitors for decoupling to AGND
V _{REFR}	28	–	Right-channel voltage reference output, requires capacitors for decoupling to AGND

ABSOLUTE MAXIMUM RATINGS

over operating free-air temperature range (unless otherwise noted)⁽¹⁾

		VALUE		UNIT
		MIN	MAX	
Supply voltage	V _{CC}	–0.3	6.5	V
	V _{DD}	–0.3	4	V
Ground voltage differences	AGND, AGNDL, AGNDR, DGND		±0.1 V	
Supply voltage difference	V _{CC} , V _{DD}		V _{CC} – V _{DD} < 3	V
Digital input voltage	FMT0, FMT1, S/M, OSR0, OSR1, OSR2, SCKI, RST	–0.3	6.5	V
	BYPAS, DATA/DSDR, BCK/DSDL, LRCK/DSD BCK, OVFL, OVFR	–0.3	V _{DD} + 0.3	V
Analog input voltage	V _{REFL} , V _{REFR} , V _{COML} , V _{COMR} , V _{INL+} , V _{INR+} , V _{INL–} , V _{INR–}	–0.3 V	V _{CC} + 0.3	V
Input current (any pins except supplies)			±10 mA	
T _A	Ambient temperature under bias	–40	125	°C
T _{stg}	Storage temperature	–55	150	°C
T _J	Junction temperature		150	°C
	Lead temperature (soldering)		260	°C, 5 s
	Package temperature (IR reflow, peak)		260	°C
ESD Rating	Human Body Model (HBM) AEC-Q100 Classification Level H2		2	kV
	Charged Device Model (CDM) AEC-Q100 750 V Classification Level C3B		750	V

(1) Stresses beyond those listed under *Absolute Maximum Ratings* may cause permanent damage to the device. These are stress ratings only, and functional operation of the device at these or any other conditions beyond those indicated under *Recommended Operating Conditions* is not implied. Exposure to absolute-maximum-rated conditions for extended periods may affect device reliability.

RECOMMENDED OPERATING CONDITIONS

over operating free-air temperature range

		MIN	NOM	MAX	UNIT
Analog supply voltage, V _{CC} ⁽¹⁾		4.75	5	5.25	V
Digital supply voltage, V _{DD}		3	3.3	3.6	V
Analog input voltage, full-scale (–0 dB), differential input			5		V _{pp}
Digital input logic family		TTL compatible			
Digital input clock frequency	System clock	8.192		36.864	MHz
	Sampling clock	32		192	kHz
Digital output load capacitance				10	pF
Operating free-air temperature, T _A		–10		70	°C

(1) If the V_{CC} drops below the minimum recommended operating condition of 4.75 V, to avoid a brown out condition the V_{CC} power must be cycled to 0 V and then to > 4.75 V to ensure continued device functionality.

ELECTRICAL CHARACTERISTICS

All specifications at $T_A = 25^\circ\text{C}$, $V_{CC} = 5\text{ V}$, $V_{DD} = 3.3\text{ V}$, master mode, single-speed mode, $f_S = 48\text{ kHz}$, system clock = $256 f_S$, 24-bit data, unless otherwise noted.

PARAMETER	TEST CONDITIONS	PCM1804DB			UNIT
		MIN	TYP	MAX	
Resolution		24			Bits
DATA FORMAT					
Audio data interface format		Standard, I ² S, left-justified			
Audio data bit length		24			Bits
Audio data format		MSB first, 2s-complement, DSD			
DIGITAL INPUT/OUTPUT					
Logic family		TTL compatible			
V_{IH} High-level input voltage	(1) (2)	2	5.5		V_{DC}
	(3)	2	V_{DD}		
V_{IL} Low-level input voltage	(1) (2) (3)	0.8			V_{DC}
I_{IH} High-level input current	$V_{IN} = V_{DD}$ (1)	65		100	μA
	$V_{IN} = V_{DD}$ (2)	± 10			
	$V_{IN} = V_{DD}$ (3)	± 100			
I_{IL} Low-level input current	$V_{IN} = 0\text{ V}$ (1) (2)	± 10			μA
	$V_{IN} = 0\text{ V}$ (3)	± 50			
V_{OH} High-level output voltage	$I_{OH} = -1\text{ mA}$ (4)	2.4			V_{DC}
V_{OL} Low-level output voltage	$I_{OL} = 1\text{ mA}$ (4)	0.4			V_{DC}
CLOCK FREQUENCY					
f_S Sampling frequency		32	192		kHz
System clock frequency	256 f_S , single rate (5)	12.288			MHz
	384 f_S , single rate (5)	18.432			
	512 f_S , single rate (5)	24.576			
	768 f_S , single rate (5)	36.864			
	256 f_S , dual rate (6)	24.576			
	384 f_S , dual rate (6)	36.864			
	128 f_S , quad rate (7)	24.576			
192 f_S , quad rate (7)	36.864				
DC ACCURACY					
Gain mismatch, channel-to-channel		± 3			% of FSR
Gain error ($V_{IN} = -0.5\text{ dB}$)		± 4			% of FSR
Bipolar zero error	HPF bypass	± 0.2			% of FSR

(1) Pins 6–11, 19: FMT0, FMT1, S/\bar{M} , OSR0, OSR1, OSR2, \overline{RST} (Schmitt-trigger input with internal pulldown (51 k Ω typically), 5-V tolerant)

(2) Pin 18: SCKI (Schmitt-trigger input, 5-V tolerant)

(3) Pins 12, 16–17: BYPAS, BCK/DSDL, LRCK/DSDBCK (in slave mode, Schmitt-trigger input)

(4) Pins 15–17, 20, and 21: DATA/DSDR, BCK/DSDL, LRCK/DSDBCK (in master mode), OVFR, OVFL

(5) Single rate, $f_S = 48\text{ kHz}$

(6) Dual rate, $f_S = 96\text{ kHz}$

(7) Quad rate, $f_S = 192\text{ kHz}$

ELECTRICAL CHARACTERISTICS (continued)

All specifications at $T_A = 25^\circ\text{C}$, $V_{CC} = 5\text{ V}$, $V_{DD} = 3.3\text{ V}$, master mode, single-speed mode, $f_S = 48\text{ kHz}$, system clock = $256 f_S$, 24-bit data, unless otherwise noted.

PARAMETER	TEST CONDITIONS	PCM1804DB			UNIT
		MIN	TYP	MAX	
DYNAMIC PERFORMANCE ⁽⁸⁾					
THD+N Total harmonic distortion plus noise	$V_{IN} = -0.5\text{ dB}$	$f_S = 48\text{ kHz}$, system clock = $256 f_S$	-102	-95	dB
	$V_{IN} = -60\text{ dB}$		-49		
	$V_{IN} = -0.5\text{ dB}$	$f_S = 96\text{ kHz}$, system clock = $256 f_S$	-101		
	$V_{IN} = -60\text{ dB}$		-47		
	$V_{IN} = -0.5\text{ dB}$	$f_S = 192\text{ kHz}$, system clock = $128 f_S$	-101		
	$V_{IN} = -60\text{ dB}$		-47		
	$V_{IN} = -0.5\text{ dB}$	DSD mode	-100		
Dynamic range (A-weighted)	$V_{IN} = -60\text{ dB}$	$f_S = 48\text{ kHz}$, system clock = $256 f_S$	106	112	dB
		$f_S = 96\text{ kHz}$, system clock = $256 f_S$	112		
		$f_S = 192\text{ kHz}$, system clock = $128 f_S$	112		
	DSD mode	112			
SNR (A-weighted)	$f_S = 48\text{ kHz}$, system clock = $256 f_S$		105	111	dB
	$f_S = 96\text{ kHz}$, system clock = $256 f_S$		111		
	$f_S = 192\text{ kHz}$, system clock = $128 f_S$		111		
	DSD mode		111		
Channel separation	$f_S = 48\text{ kHz}$, system clock = $256 f_S$		97	109	dB
	$f_S = 96\text{ kHz}$, system clock = $256 f_S$		107		
	$f_S = 192\text{ kHz}$, system clock = $128 f_S$		107		
ANALOG INPUT					
Input voltage	Differential input	± 2.5			V
Center voltage		2.5			V_{DC}
Input impedance	Single-ended	10			k μ
DIGITAL FILTER PERFORMANCE					
Pass-band edge	Single rate, dual rate	0.453 f_S			Hz
Stop-band edge	Single rate, dual rate	0.547 f_S			Hz
Pass-band ripple	Single rate, dual rate	± 0.005			dB
Stop-band attenuation	Single rate, dual rate	-100			dB
Pass-band edge (-0.005 dB)	Quad rate	0.375 f_S			Hz
Pass-band edge (-3 dB)	Quad rate	0.49 f_S			Hz
Stop-band edge	Quad rate	0.77 f_S			Hz
Pass-band ripple	Quad rate	± 0.005			dB
Stop-band attenuation	Quad rate	-135			dB
Group delay	Single rate, dual rate	37/ f_S			s
Group delay	Quad rate	9.5/ f_S			s
HPF frequency response	-3 dB	$f_S/48000$			Hz

(8) The $f_{IN} = 1\text{ kHz}$, using System Two™ audio measurement system by Audio Precision™ in RMS mode, with 20-kHz LPF and 400-Hz HPF in calculation for single rate, or with 40-kHz LPF in calculation for dual and quad rates .

ELECTRICAL CHARACTERISTICS (continued)

All specifications at $T_A = 25^\circ\text{C}$, $V_{CC} = 5\text{ V}$, $V_{DD} = 3.3\text{ V}$, master mode, single-speed mode, $f_S = 48\text{ kHz}$, system clock = $256 f_S$, 24-bit data, unless otherwise noted.

PARAMETER	TEST CONDITIONS	PCM1804DB			UNIT
		MIN	TYP	MAX	
POWER SUPPLY REQUIREMENTS					
V_{CC}	Supply voltage range	4.75	5	5.25	V_{DC}
V_{DD}		3	3.3	3.6	
I_{CC}	Supply current	$V_{CC} = 5\text{ V}$ ⁽⁹⁾ ⁽¹⁰⁾ ⁽¹¹⁾		35	45
I_{DD}		$V_{DD} = 3.3\text{ V}$ ⁽⁹⁾ ⁽¹²⁾		15	20
		$V_{DD} = 3.3\text{ V}$ ⁽¹⁰⁾ ⁽¹²⁾		27	
		$V_{DD} = 3.3\text{ V}$ ⁽¹¹⁾ ⁽¹²⁾		18	
P_D	Power dissipation	Operation, $V_{CC} = 5\text{ V}$, $V_{DD} = 3.3\text{ V}$ ⁽⁹⁾ ⁽¹²⁾		225	290
		Operation, $V_{CC} = 5\text{ V}$, $V_{DD} = 3.3\text{ V}$ ⁽¹⁰⁾ ⁽¹²⁾		265	
		Operation, $V_{CC} = 5\text{ V}$, $V_{DD} = 3.3\text{ V}$ ⁽¹¹⁾ ⁽¹²⁾		235	
		Power down, $V_{CC} = 5\text{ V}$, $V_{DD} = 3.3\text{ V}$		5	
TEMPERATURE RANGE					
	Operation temperature	-10		70	$^\circ\text{C}$
θ_{JA}	Thermal resistance		100		$^\circ\text{C/W}$

(9) Single rate, $f_S = 48\text{ kHz}$

(10) Dual rate, $f_S = 96\text{ kHz}$

(11) Quad rate, $f_S = 192\text{ kHz}$

(12) Minimum load on DATA/DSDR (pin 15)

TYPICAL PERFORMANCE CURVES - SINGLE RATE

All specifications at $T_A = 25^\circ\text{C}$, $V_{CC} = 3.3\text{ V}$, $V_{DD} = 5\text{ V}$, master mode, $f_S = 48\text{ kHz}$, system clock = $256 f_S$, 24-bit data, unless otherwise noted.

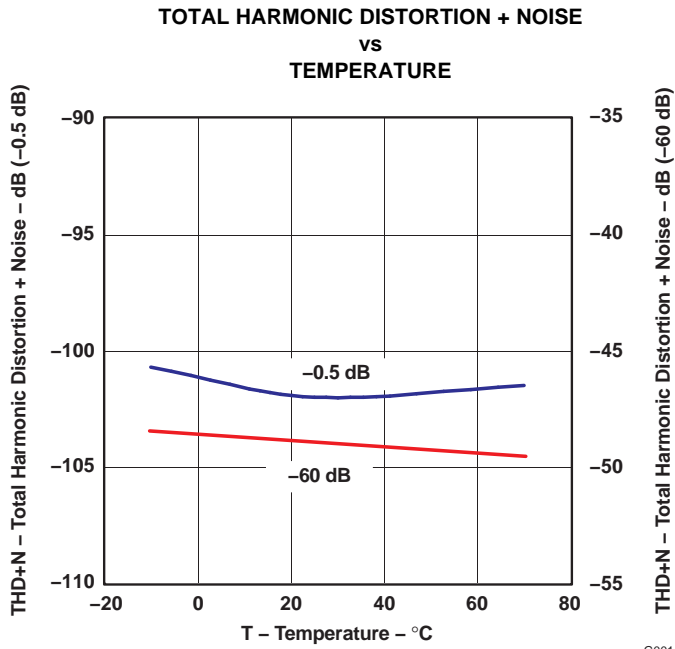

Figure 1.

G001

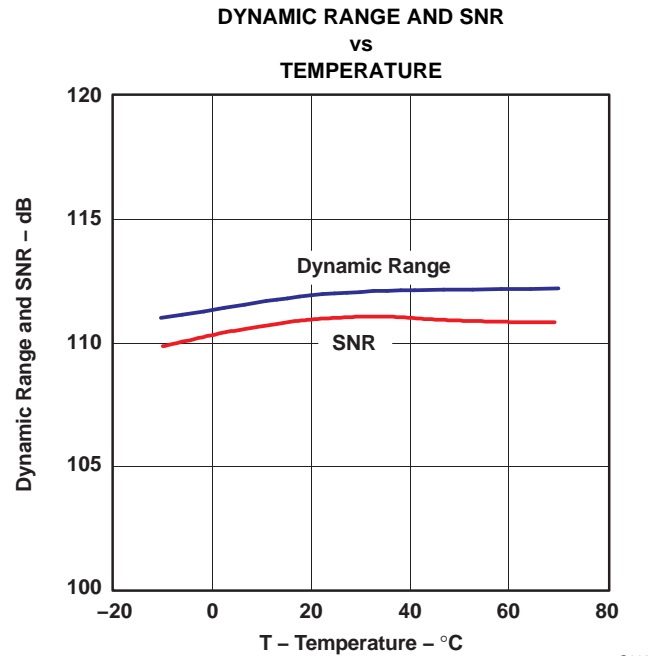

Figure 2.

G002

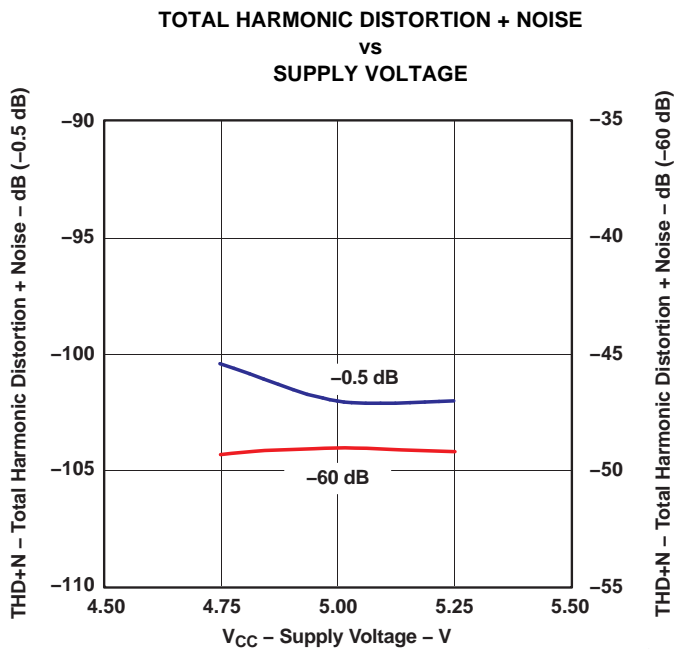

Figure 3.

G003

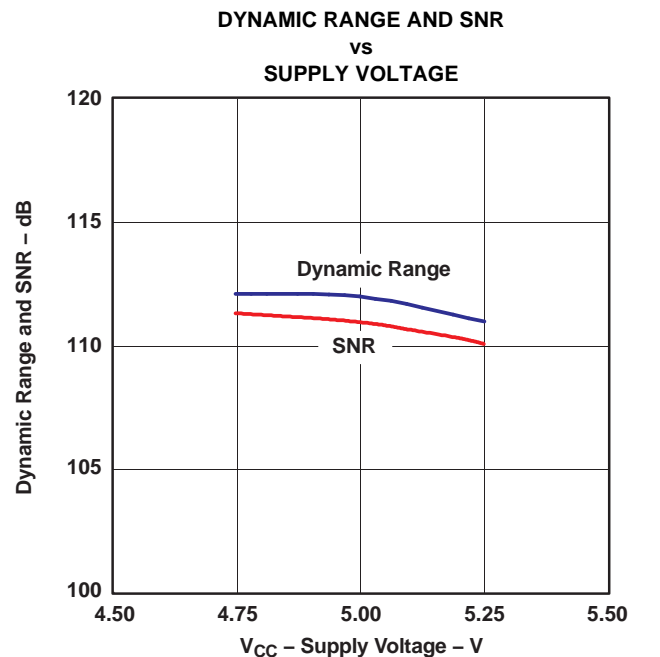

Figure 4.

G004

TYPICAL PERFORMANCE CURVES - SINGLE RATE (continued)

All specifications at $T_A = 25^\circ\text{C}$, $V_{CC} = 3.3\text{ V}$, $V_{DD} = 5\text{ V}$, master mode, $f_s = 48\text{ kHz}$, system clock = $256 f_s$, 24-bit data, unless otherwise noted.

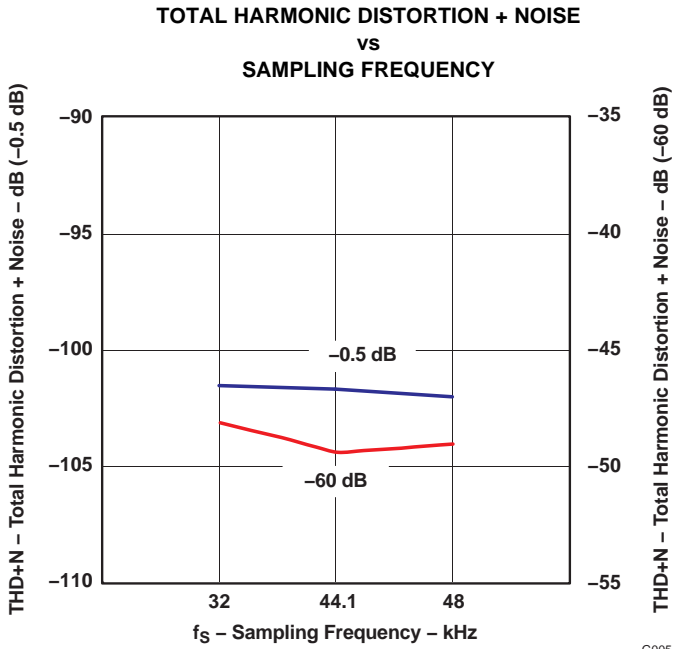

Figure 5.

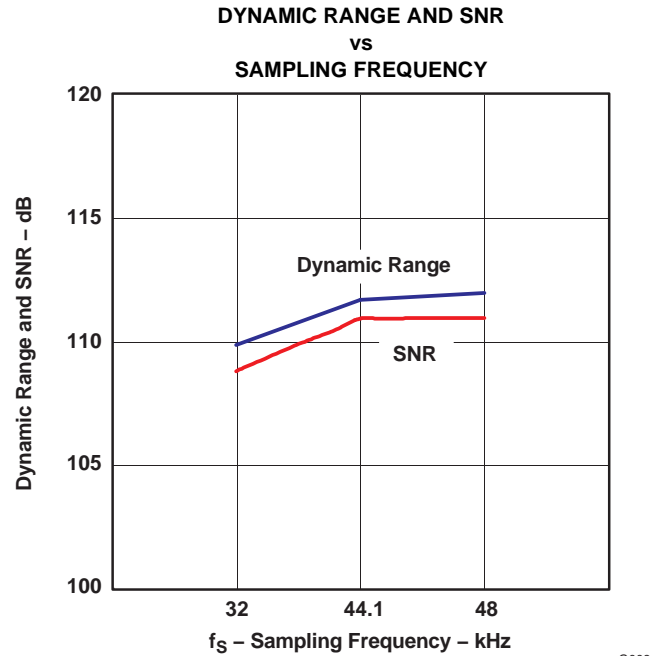

Figure 6.

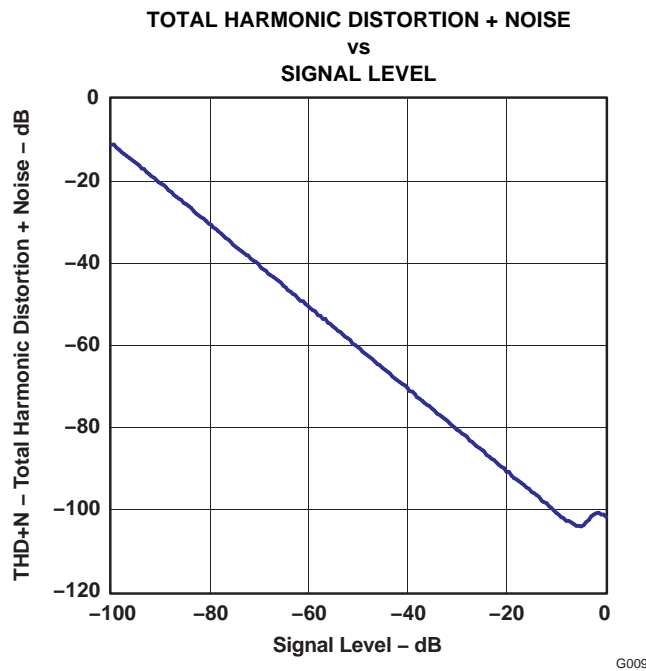

Figure 7.

TYPICAL PERFORMANCE CURVES - SINGLE RATE (continued)

All specifications at $T_A = 25^\circ\text{C}$, $V_{CC} = 3.3\text{ V}$, $V_{DD} = 5\text{ V}$, master mode, $f_S = 48\text{ kHz}$, system clock = $256 f_S$, 24-bit data, unless otherwise noted.

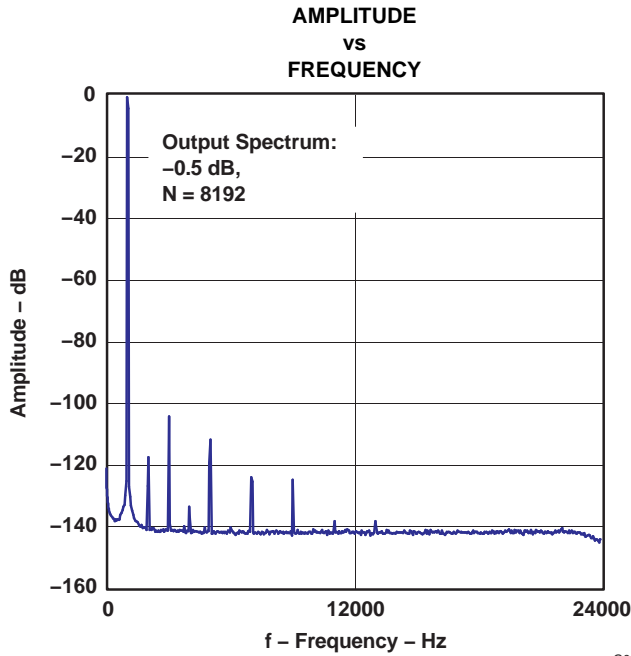

Figure 8.

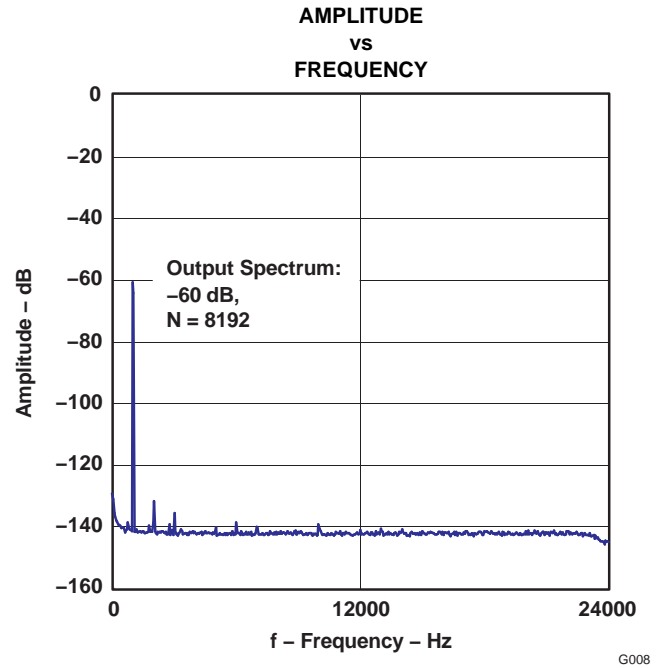

Figure 9.

TYPICAL PERFORMANCE CURVES - DUAL RATE

All specifications at $T_A = 25^\circ\text{C}$, $V_{CC} = 3.3\text{ V}$, $V_{DD} = 5\text{ V}$, master mode, and 24-bit data, unless otherwise noted.

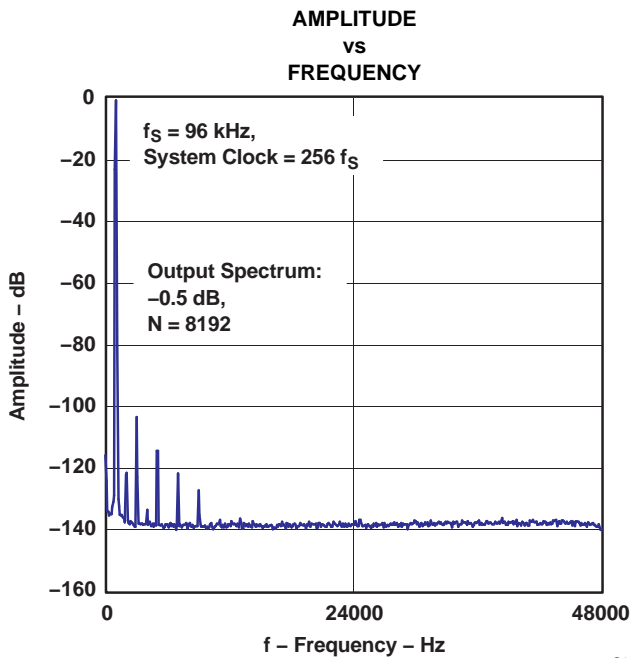

Figure 10.

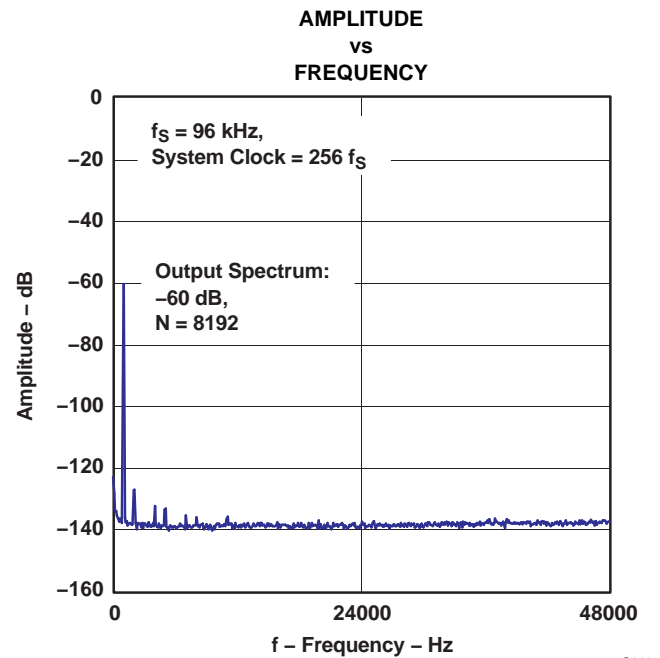

Figure 11.

TYPICAL PERFORMANCE CURVES - QUAD RATE

All specifications at $T_A = 25^\circ\text{C}$, $V_{CC} = 3.3\text{ V}$, $V_{DD} = 5\text{ V}$, master mode, 24-bit data, unless otherwise noted.

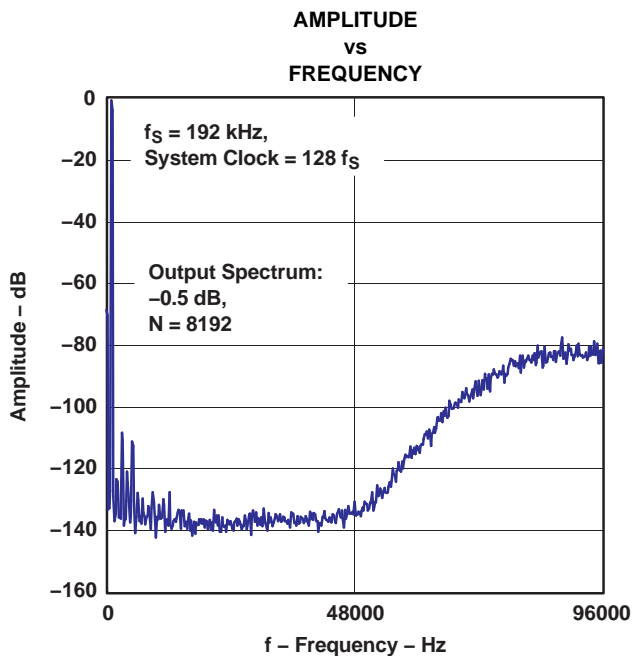

Figure 12.

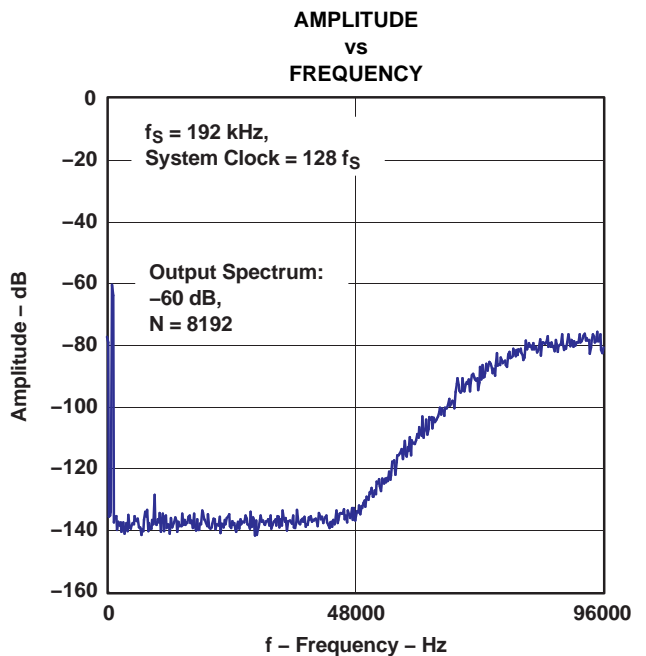

Figure 13.

TYPICAL PERFORMANCE CURVES - DSD MODE

All specifications at $T_A = 25^\circ\text{C}$, $V_{CC} = 3.3\text{ V}$, $V_{DD} = 5\text{ V}$, master mode, $f_S = 44.1\text{ kHz}$, system clock = 16.9344 MHz, unless otherwise noted.

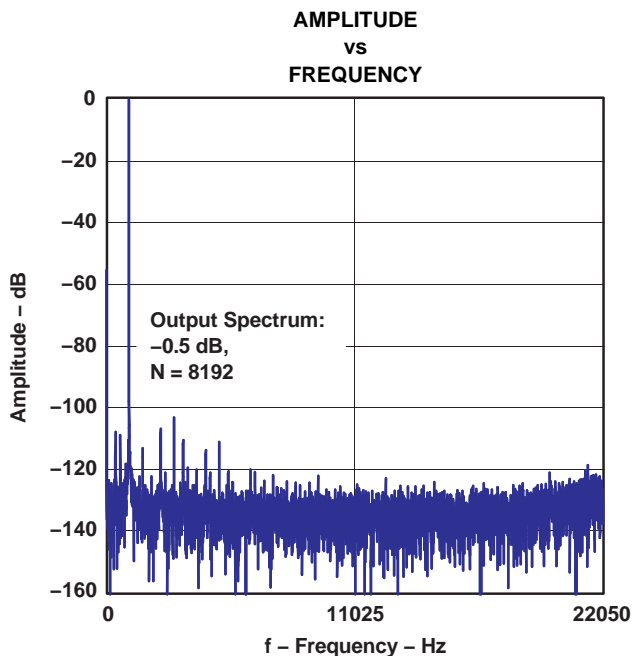

Figure 14.

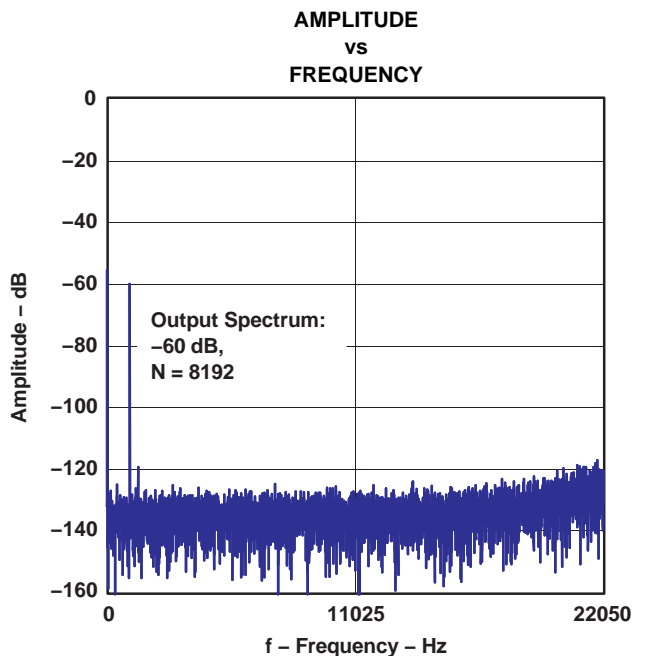

Figure 15.

TYPICAL PERFORMANCE CURVES OF INTERNAL FILTER

LINEAR PHASE ANTIALIAS DIGITAL FILTER FREQUENCY RESPONSE - Single Rate

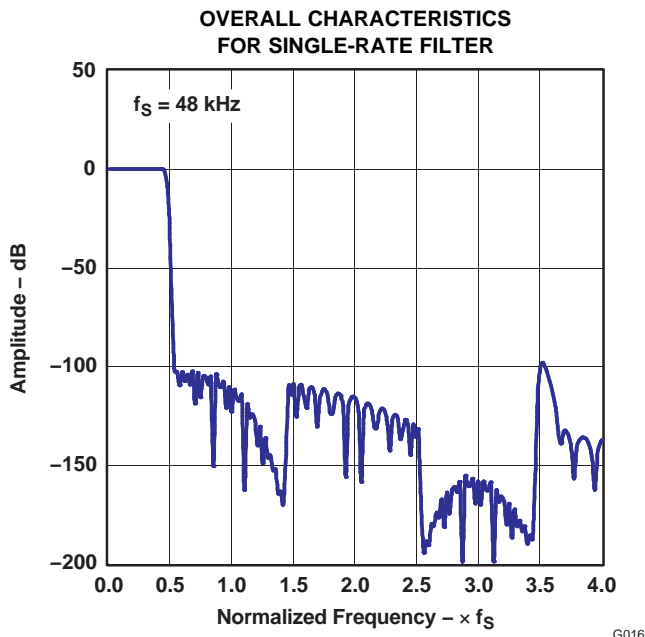

Figure 16.

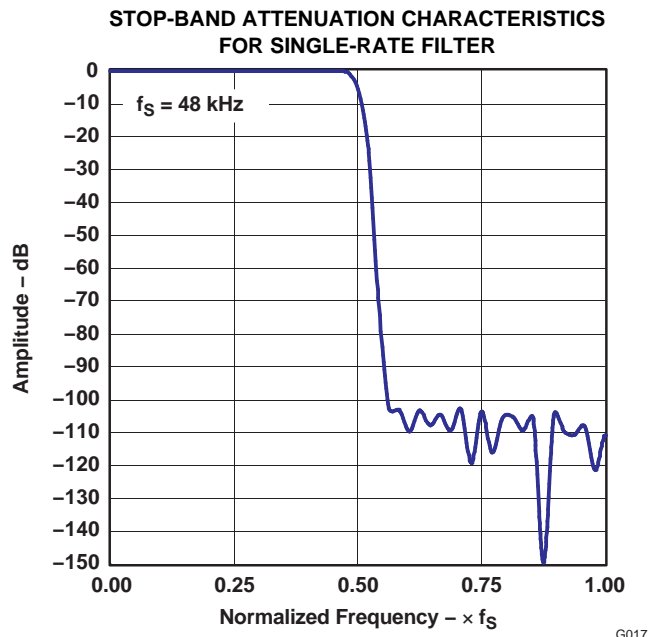

Figure 17.

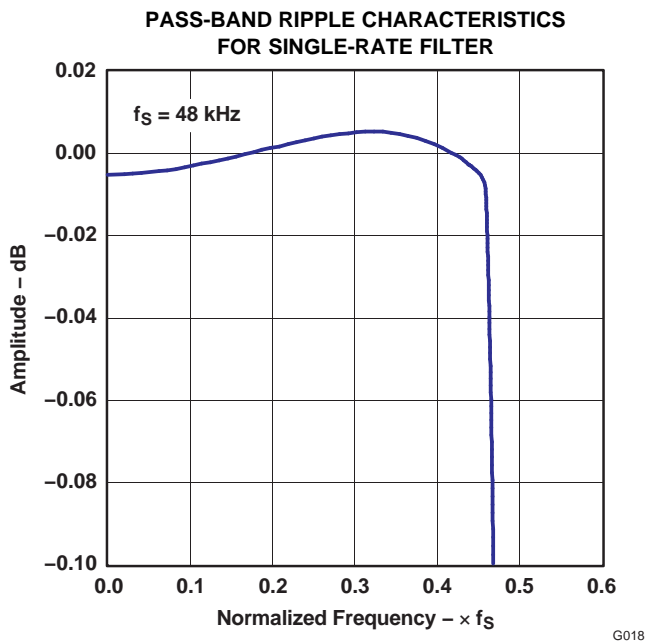

Figure 18.

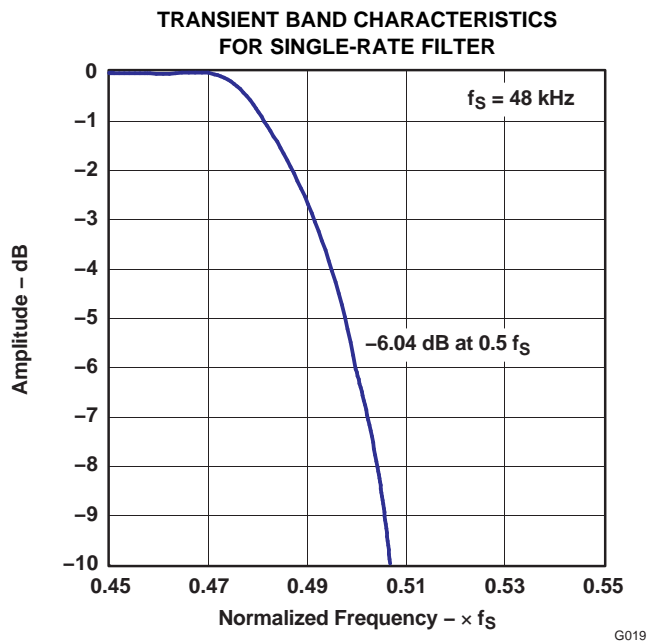

Figure 19.

TYPICAL PERFORMANCE CURVES OF INTERNAL FILTER (continued)
LINEAR PHASE ANTIALIAS DIGITAL FILTER FREQUENCY RESPONSE - Dual Rate

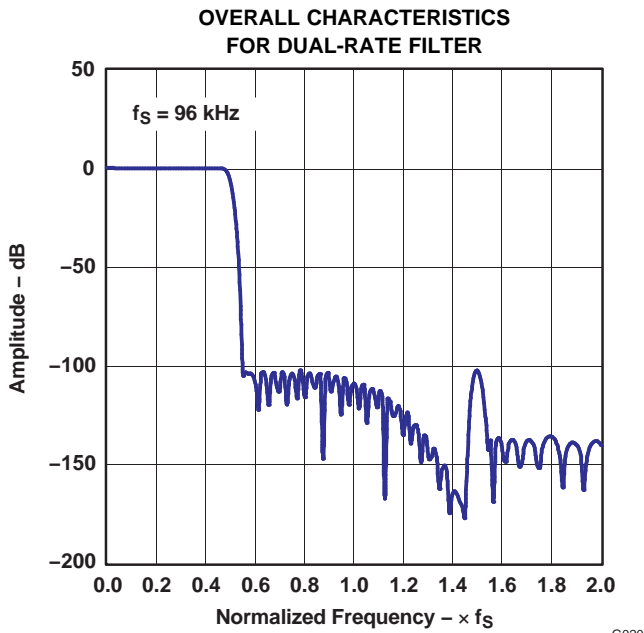

Figure 20.

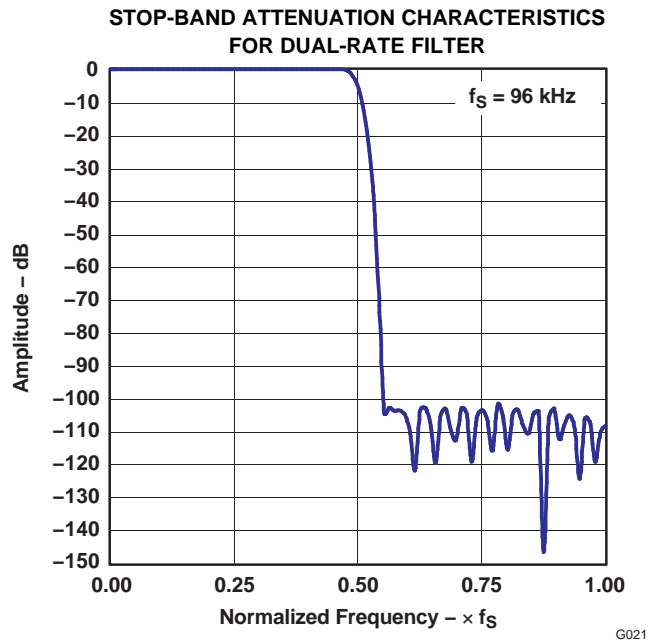

Figure 21.

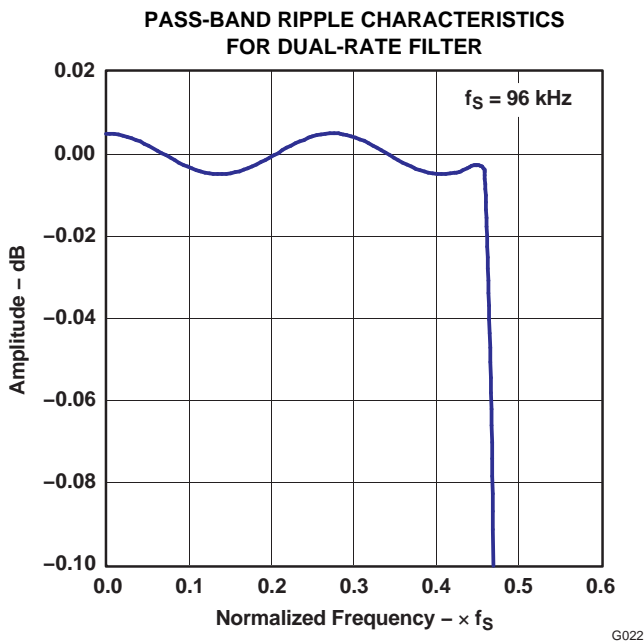

Figure 22.

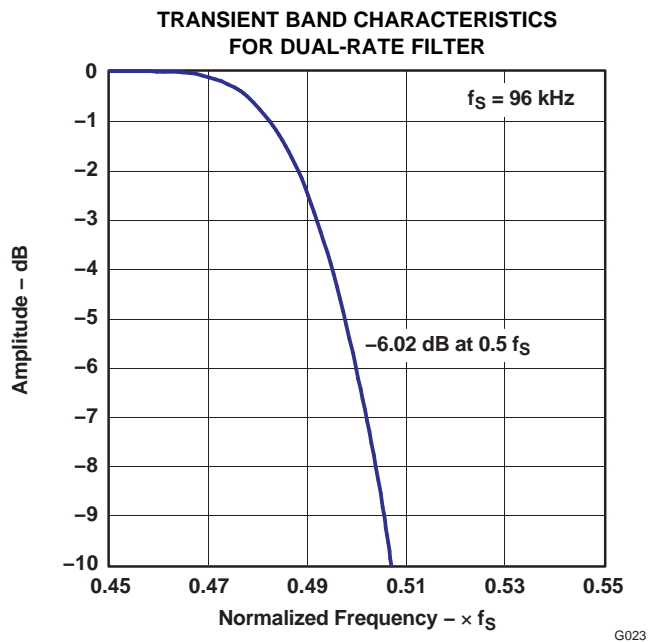

Figure 23.

TYPICAL PERFORMANCE CURVES OF INTERNAL FILTER (continued)
LINEAR PHASE ANTIALIAS DIGITAL FILTER FREQUENCY RESPONSE - Quad Rate

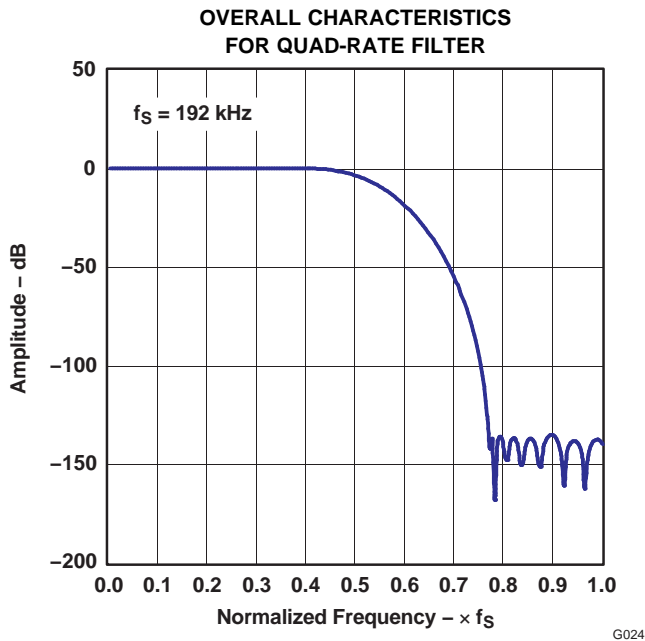

Figure 24.

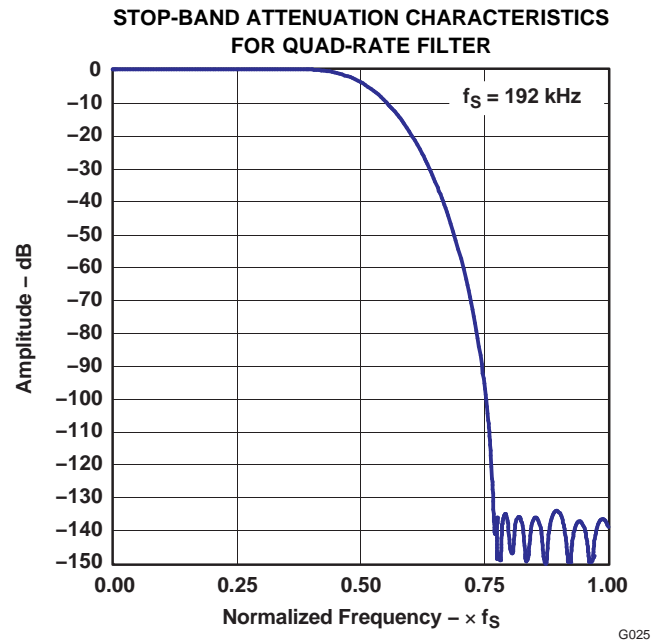

Figure 25.

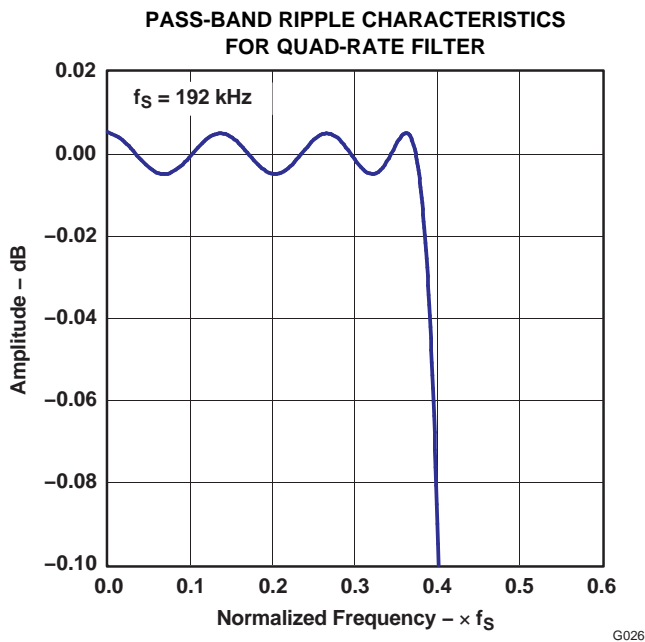

Figure 26.

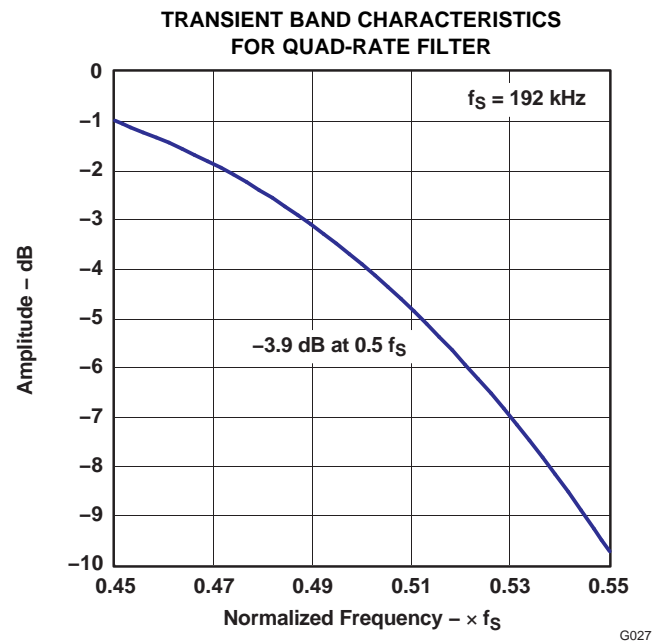

Figure 27.

**TYPICAL PERFORMANCE CURVES OF INTERNAL FILTER (continued)
HIGH-PASS FILTER (HPF) FREQUENCY RESPONSE**

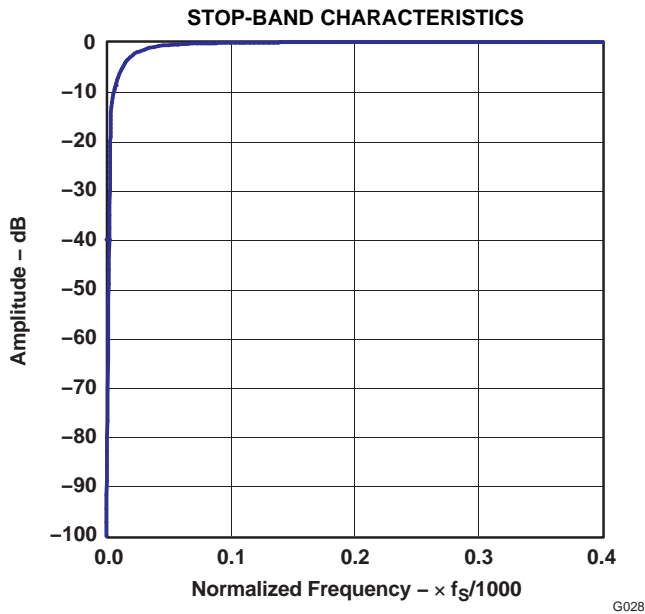

Figure 28.

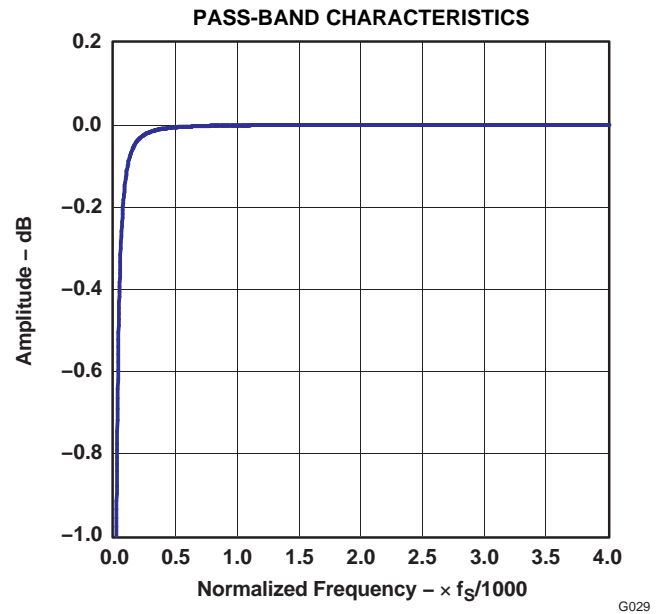

Figure 29.

PRINCIPLES OF OPERATION

THEORY OF OPERATION

The PCM1804-Q1 device consists of a band-gap reference, a delta-sigma modulator with full-differential architecture for L-channel and R-channel, a decimation filter with a high-pass filter, and a serial interface circuit. [Figure 30](#) illustrates the total architecture of the PCM1804-Q1 device. An on-chip, high-precision reference with 10- μ F external capacitor(s) provides all the reference voltage needed in the PCM1804-Q1 device, and it defines the full-scale voltage range of both channels. Full-differential architecture provides a wide dynamic range and excellent power-supply rejection performance. The input signal is sampled at $\times 128$, $\times 64$, and $\times 32$ oversampling rates according to the oversampling ratio control, OSR[0:2]. The single rate, dual rate, and quad rate eliminate the external sample-and-hold amplifier. [Figure 31](#) illustrates how for each oversampling ratio the PCM1804-Q1 device decimates, the modulator outputs down to PCM data when the modulator is running at 6.144 MHz. The delta-sigma modulation randomizes the modulator outputs and reduces the idle-tone level. The oversampled data stream from the delta-sigma modulator is converted to a $1-f_s$, 24-bit digital signal, while removing high-frequency noise components using a decimation filter. The DC components of the signal are removed by the HPF, and the HPF output is converted to a time-multiplexed serial signal through the serial interface, which provides flexible serial formats as well as master and slave modes. The PCM1804-Q1 device also has a DSD output mode. The PCM1804-Q1 device can output the signal directly from the modulators to DSDL (pin 16) and DSDR (pin 15).

PRINCIPLES OF OPERATION (continued)

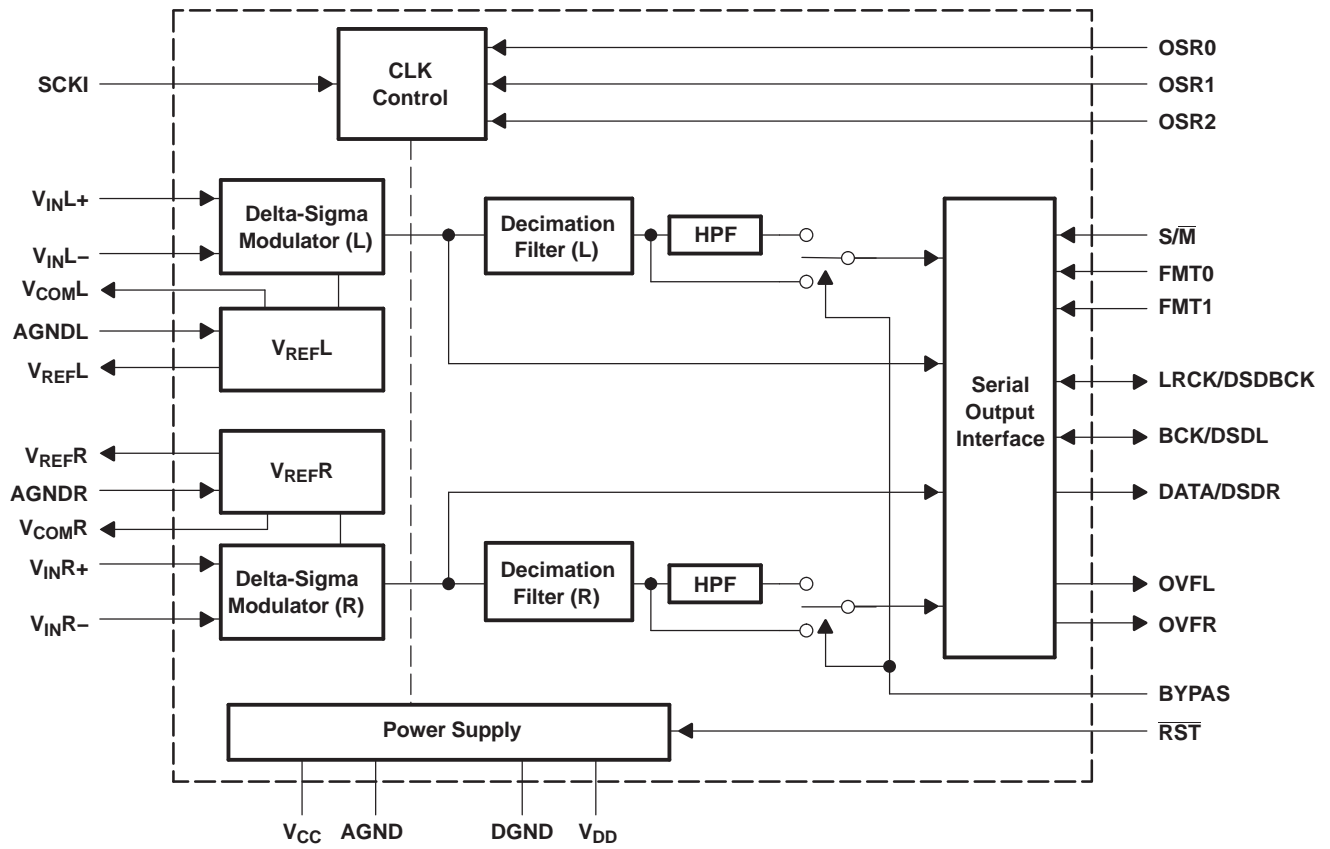

B0029-01

Figure 30. Total Block Diagram of the PCM1804-Q1 Device

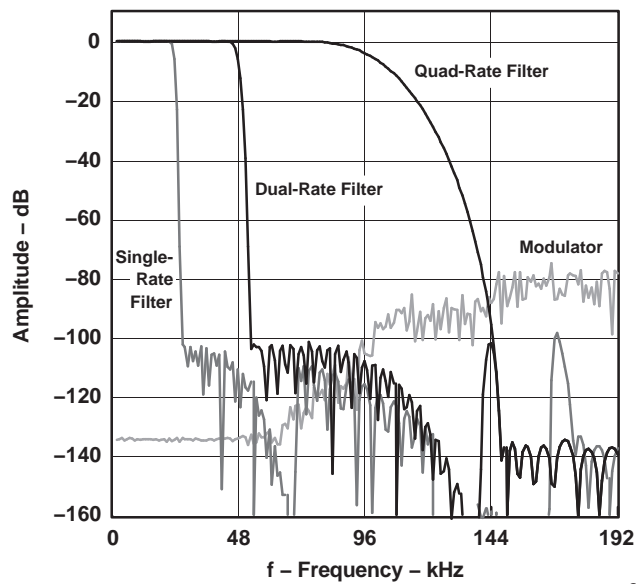

G030

Figure 31. Spectrum of Modulator Output and Decimation Filter

PRINCIPLES OF OPERATION (continued)

SYSTEM CLOCK INPUT

The PCM1804-Q1 device supports $128 f_s$, $192 f_s$ (only in master mode at quad rate), $256 f_s$, $384 f_s$, $512 f_s$, and $768 f_s$ as a system clock, where f_s is the audio sampling frequency. The system clock must be supplied on SCKI (pin 18). Table 3 shows the relationship of typical sampling frequency and the system clock frequency, and Figure 32 shows system clock timing. In master mode, the system clock rate is selected by OSR2 (pin 11), OSR1 (pin 10), and OSR0 (pin 9) as shown in Table 1. In slave mode, the system clock rate is automatically detected. In DSD mode, OSR2 (pin 11), OSR1 (pin 10), OSR0 (pin 9), and the system clock frequency are fixed as shown in Table 1 and Table 3.

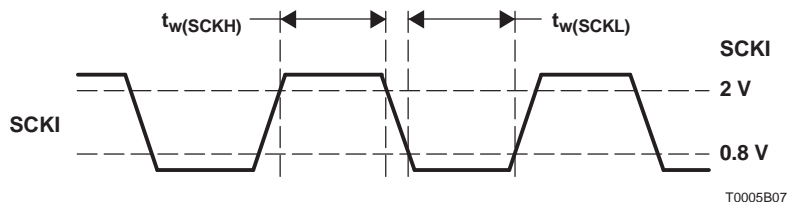

PARAMETER		MIN	UNIT
$t_w(SCKH)$	System clock pulse duration, HIGH	11	ns
$t_w(SCKL)$	System clock pulse duration, LOW	11	ns

Figure 32. System Clock Input Timing

POWER-ON AND RESET FUNCTIONS

The PCM1804-Q1 device has both an internal power-on-reset circuit and \overline{RST} (pin 19). For internal power-on reset, initialization (reset) is performed automatically at the time when the digital power supply exceeds 2 V (typical) and analog power supply exceeds 4 V (typical). \overline{RST} accepts external forced reset, and a low level on \overline{RST} initiates the reset sequence. Because an internal pulldown resistor terminates \overline{RST} , no connection of \overline{RST} is equivalent to a low-level input. Because the system clock is used as a clock signal for the reset circuit, the system clock must be supplied as soon as power is supplied; more specifically, at least three system clocks are required prior to $V_{DD} > 2 V$, $V_{CC} > 4 V$, and $\overline{RST} = \text{high}$. While $V_{DD} < 2 V$ (typical), $V_{CC} < 4 V$ (typical), or $\overline{RST} = \text{low}$, and $1 / f_s$ (maximum) count after $V_{DD} > 2 V$ (typical), $V_{CC} > 4 V$ (typical) and $\overline{RST} = \text{high}$, the PCM1804-Q1 device stays in the reset state and the digital output is forced to zero. The digital output is valid after the reset state is released and the time of $1116 / f_s$ has passed. Figure 33 and Figure 34 illustrate the internal power-on-reset and external-reset timing, respectively. Figure 35 illustrates the digital output for power-on reset and \overline{RST} control. The PCM1804-Q1 needs $\overline{RST} = \text{low}$ when control pins are changed or in slave mode when SCKI, LRCK, and BCK are changed.

POWER-DOWN FUNCTION

The PCM1804-Q1 device has a power-down feature that is controlled by \overline{RST} (pin 19). Entering the power-down mode is done by keeping the \overline{RST} input level low for more than $65536 / f_s$. In the master mode, the SCKI (pin 18) is used as the clock signal for the power-down counter. While in the slave mode, SCKI (pin 18) and LRCK (pin 17) are used as the clock signal. The clock(s) must be supplied until the power-down sequence completes. As soon as \overline{RST} goes high, the PCM1804-Q1 device starts the reset-release sequence described in the Power-On and Reset Functions section.

OVERSAMPLING RATIO

The oversampling ratio is selected by OSR2 (pin 11), OSR1 (pin 10), and OSR0 (pin 9) as shown in Table 1 and Table 2. The PCM1804-Q1 device needs \overline{RST} to equal low when logic levels on the OSR2, OSR1, and OSR0 pins are changed.

Table 1. Oversampling Ratio in Master Mode

OSR2	OSR1	OSR0	OVERSAMPLING RATIO	SYSTEM CLOCK RATE
Low	Low	Low	Single rate ($\times 128 f_S$)	$768 f_S$
Low	Low	High	Single rate ($\times 128 f_S$)	$512 f_S$
Low	High	Low	Single rate ($\times 128 f_S$)	$384 f_S$
Low	High	High	Single rate ($\times 128 f_S$)	$256 f_S$
High	Low	Low	Dual rate ($\times 64 f_S$)	$384 f_S$
High	Low	High	Dual rate ($\times 64 f_S$)	$256 f_S$
High	High	Low	Quad rate ($\times 32 f_S$)	$192 f_S$
High	High	High	Quad rate ($\times 32 f_S$)	$128 f_S$
High	Low	Low	DSD mode ($\times 64 f_S$)	$384 f_S$
High	Low	High	DSD mode ($\times 64 f_S$)	$256 f_S$

Table 2. Oversampling Ratio in Slave Mode

OSR2	OSR1	OSR0	OVERSAMPLING RATIO	SYSTEM CLOCK RATE
Low	Low	Low	Single rate ($\times 128 f_S$)	Automatically detected
Low	Low	High	Dual rate ($\times 64 f_S$)	Automatically detected
Low	High	Low	Quad rate ($\times 32 f_S$) ⁽¹⁾	Automatically detected
Low	High	High	Reserved	–
High	Low	Low	Reserved	–
High	Low	High	Reserved	–
High	High	Low	Reserved	–
High	High	High	Reserved	–

(1) Only at the $128\text{-}f_S$ system clock rate**Table 3. Sampling Frequency and System Clock Frequency**

OVERSAMPLING RATIO	SAMPLING FREQUENCY (kHz)	SYSTEM CLOCK FREQUENCY (MHz)					
		$128 f_S$	$192 f_S$ ⁽¹⁾	$256 f_S$	$384 f_S$	$512 f_S$	$768 f_S$
Single rate ⁽²⁾	32	–	–	8.192	12.288	16.384	24.576
	44.1	–	–	11.2896	16.9344	22.5792	33.8688
	48	–	–	12.288	18.432	24.576	36.864
Dual rate ⁽³⁾	88.2	–	–	22.5792	33.8688	–	–
	96	–	–	24.576	36.864	–	–
Quad rate ⁽⁴⁾	176.4	22.5792	33.8688	–	–	–	–
	192	24.576	36.864	–	–	–	–
DSD mode ⁽³⁾	44.1	–	–	11.2896	16.9344	–	–

(1) Only available in master mode at the quad rate

(2) Modulator is running at $128 f_S$.(3) Modulator is running at $64 f_S$.(4) Modulator is running at $32 f_S$.

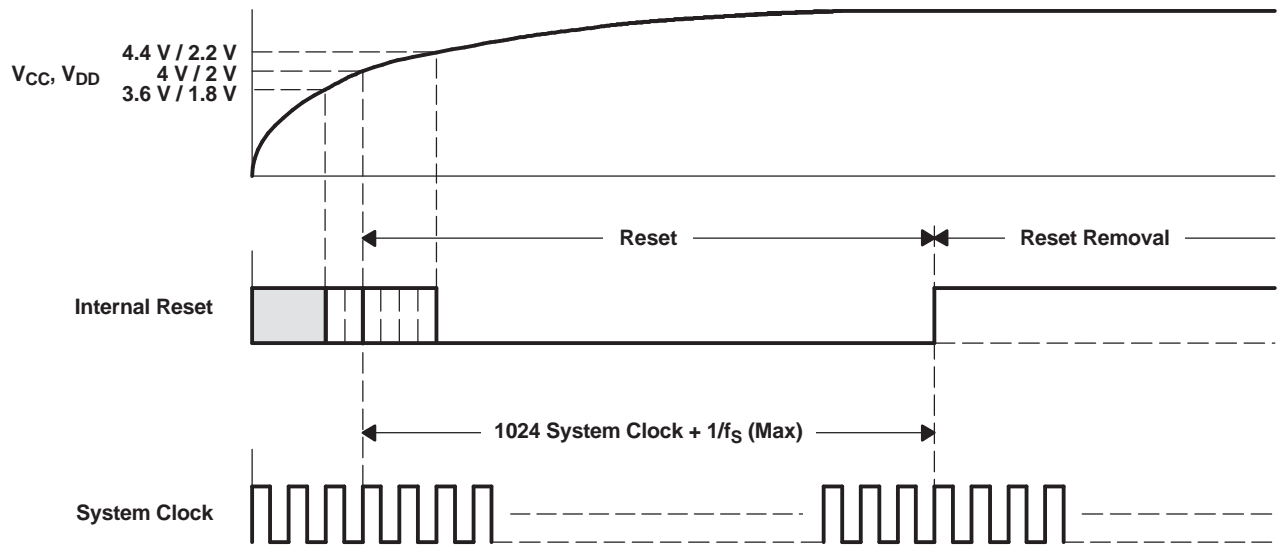

T0014-07

Figure 33. Internal Power-On-Reset Timing

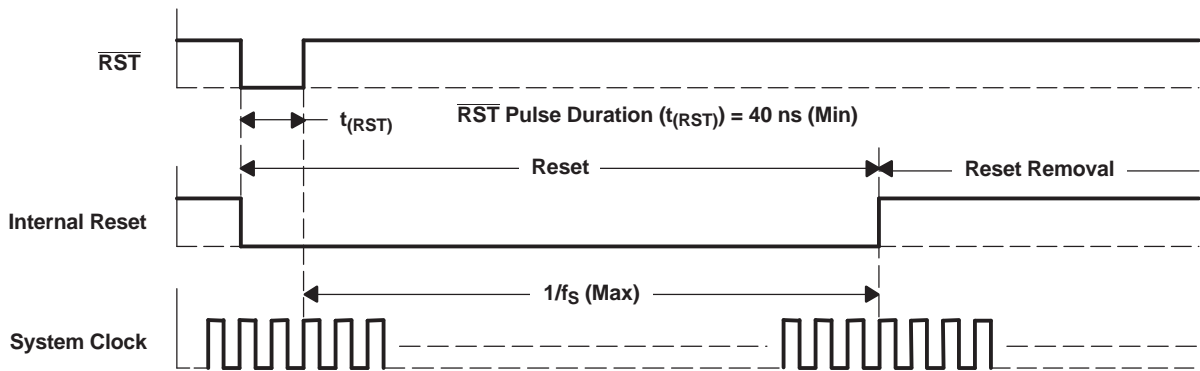

T0015-05

Figure 34. External-Reset Timing

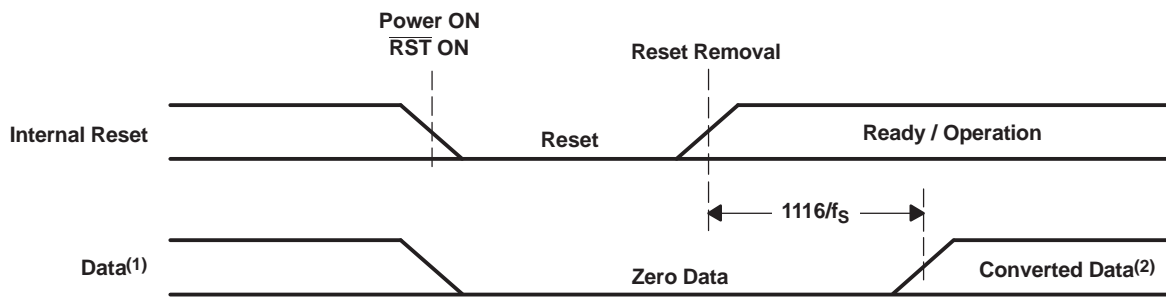

T0051-01

- (1) In the DSD mode, DSDL is also controlled like DSDR.
- (2) The HPF transient response appears initially.

Figure 35. ADC Digital Output for Power-On-Reset and $\overline{\text{RST}}$ Control

AUDIO DATA INTERFACE

The PCM1804-Q1 device interfaces the audio system through BCK/DSDL (pin 16), LRCK/DSDBCK (pin 17), and DATA/DSDR (pin 15). The PCM1804-Q1 device needs $\overline{\text{RST}}$ to equal low in the interface mode and/or if the data format is changed.

INTERFACE MODE

The PCM1804-Q1 device supports master mode and slave mode as interface modes, which are selected by $\overline{\text{S/M}}$ (pin 8) as shown in [Table 4](#). In master mode, the PCM1804-Q1 device provides the timing of the serial audio data communications between the PCM1804-Q1 device and the digital audio processor or external circuit. While in slave mode, the PCM1804-Q1 device receives the timing for data transfer from an external controller. Slave mode is not available for DSD.

Table 4. Interface Mode

$\overline{\text{S/M}}$	MODE
Low	Master mode
High	Slave mode

DATA FORMAT

The PCM1804-Q1 device supports four audio data formats in both master and slave modes, and these data formats are selected by FMT0 (pin 6) and FMT1 (pin 7) as shown in [Table 5](#).

Table 5. Data Format

FMT1	FMT0	FORMAT	MASTER	SLAVE
Low	Low	PCM, left-justified, 24-bit	Yes	Yes
Low	High	PCM, I ² S, 24-bit	Yes	Yes
High	Low	PCM, standard, 24-bit	Yes	Yes
High	High	DSD	Yes	–

INTERFACE TIMING FOR PCM

Figure 36 through Figure 38 show the interface timing for PCM.

(1) Left-Justified Data Format; L-Channel = High, R-Channel = Low

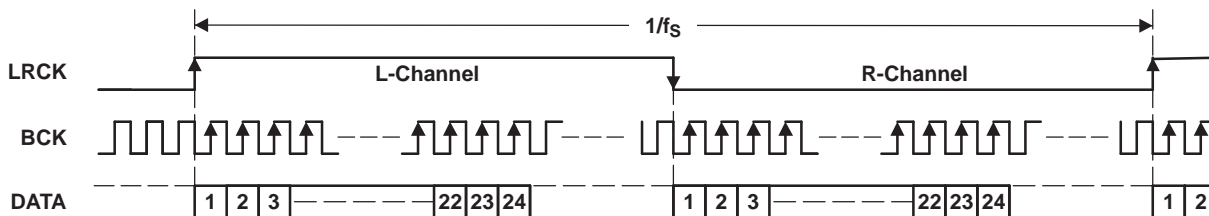

(2) I²S Data Format; L-Channel = Low, R-Channel = High

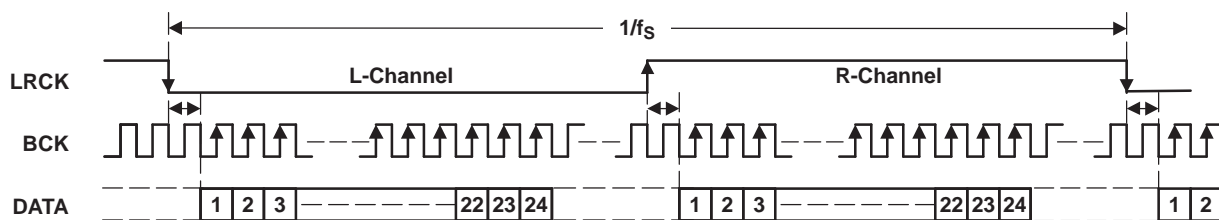

(3) Standard Data Format; L-Channel = High, R-Channel = Low

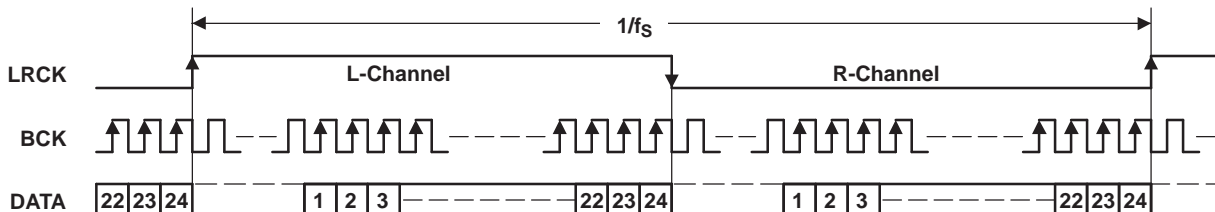

T0009-03

NOTE: LRCK and BCK work as outputs in master mode and as inputs in slave mode.

Figure 36. Audio Data Format for PCM

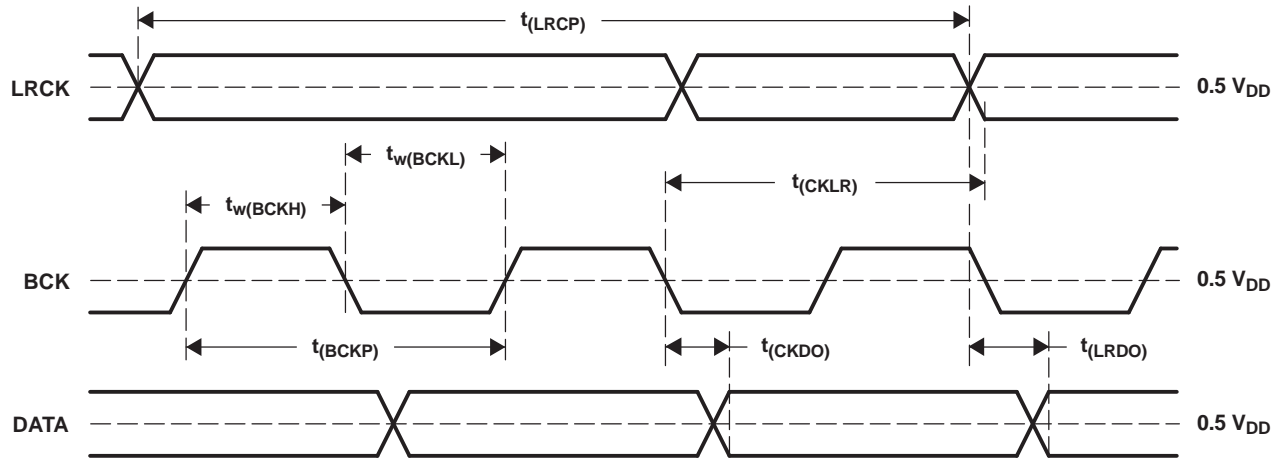

T0018-03

PARAMETERS		MIN	TYP	MAX	UNIT
$t_{(BCKP)}$	BCK period		$1 / (64 f_S)$		
$t_{w(BCKH)}$	BCK pulse duration, HIGH	32			ns
$t_{w(BCKL)}$	BCK pulse duration, LOW	32			ns
$t_{(CKLR)}$	Delay time, BCK falling edge to LRCK valid	-5		15	ns
$t_{(LRCP)}$	LRCK period		$1 / f_S$		
$t_{(CKDO)}$	Delay time, BCK falling edge to DATA valid	-5		15	ns
$t_{(LRDO)}$	Delay time, LRCK edge to DATA valid	-5		15	ns
t_r	Rising time of all signals			10	ns
t_f	Falling time of all signals			10	ns

- (1) Rising and falling times are measured from 10% to 90% of IN/OUT signal swing.
- (2) The load capacitance of all signals is 10 pF.
- (3) The $t_{(BCKP)}$ is fixed at $1 / (64 f_S)$ in case of master mode.

Figure 37. Audio Data Interface Timing for PCM (Master Mode: LRCK and BCK Work as Outputs)

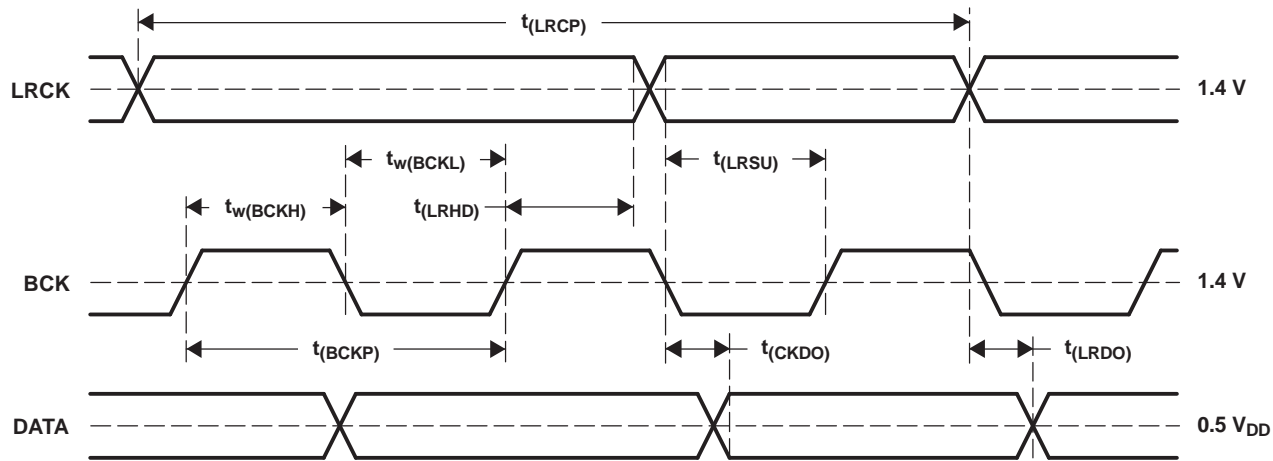

T0017-03

PARAMETERS		MIN	TYP	MAX	UNIT
$t_{(BCKP)}$	BCK period	$1 / (64 f_S)$		$1 / (48 f_S)$	
$t_{w(BCKH)}$	BCK pulse duration, HIGH	32			ns
$t_{w(BCKL)}$	BCK pulse duration, LOW	32			ns
$t_{(LRSU)}$	LRCK setup time to BCK rising edge	12			ns
$t_{(LRHD)}$	LRCK hold time to BCK rising edge	12			ns
$t_{(LRCP)}$	LRCK period		$1 / f_S$		
$t_{(CKDO)}$	Delay time, BCK falling edge to DATA valid	5		25	ns
$t_{(LRDO)}$	Delay time, LRCK edge to DATA valid	5		25	ns
t_r	Rising time of all signals			10	ns
t_f	Falling time of all signals			10	ns

- (1) Rising and falling times are measured from 10% to 90% of IN/OUT signals swing.
- (2) The load capacitance of the DATA /DSDR signal is 10 pF.

Figure 38. Audio Data Interface Timing for PCM (Slave Mode: LRCK and BCK Work as Inputs)

INTERFACE TIMING FOR DSD

Figure 39 and Figure 40 show the interface timing for DSD.

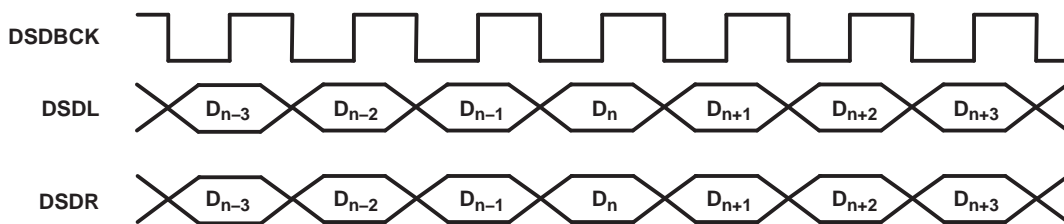

T0052-01

Figure 39. Audio Data Format

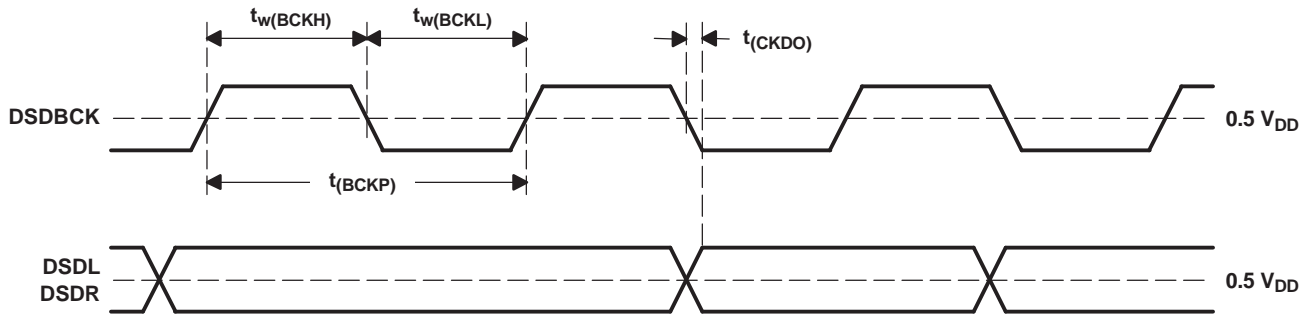

T0053-01

PARAMETERS		MIN	TYP	MAX	UNIT
$t_{(BCKP)}$	DSD BCK period		354		ns
$t_{w(BCKH)}$	DSD BCK pulse duration, HIGH		177		ns
$t_{w(BCKL)}$	DSD BCK pulse duration, LOW		177		ns
$t_{(CKDO)}$	Delay time DSD BCK falling edge to DSDL, DSDR valid	-5		15	ns
t_r	Rising time of all signals			10	ns
t_f	Falling time of all signals			10	ns

- (1) Rising and falling times are measured from 10% to 90% of IN/OUT signal swing.
- (2) The load capacitance of the DSD BCK, DSDL, and DSDR signal is 10 pF.

Figure 40. Audio Data Interface Timing for DSD (Master Mode Only)

SYNCHRONIZATION WITH DIGITAL AUDIO SYSTEM FOR PCM

In slave mode, the PCM1804-Q1 device operates under LRCK synchronized with the system clock SCKI. The PCM1804-Q1 device does not need a specific phase relationship between LRCK and SCKI, but it does require the synchronization of LRCK and SCKI.

If the relationship between LRCK and SCKI changes more than ± 6 BCK during one sample period due to LRCK or SCKI jitter, internal operation of the ADC halts within $1 / f_s$ and digital output is forced into BPZ code until resynchronization between LRCK and SCKI is completed.

For changes less than ± 5 BCK, resynchronization does not occur and the previously described digital output control and discontinuity do not occur.

Figure 41 shows the ADC digital output for loss of synchronization and resynchronization. During undefined data, the PCM1804-Q1 device may generate some noise in the audio signal. Also, the transition of normal to undefined data and undefined or zero data to normal causes a discontinuity of data on the digital output. This can generate noise in the audio signal. In master mode, synchronization loss never occurs.

HIGH-PASS FILTER (HPF) BYPASS CONTROL FOR PCM

The built-in function for DC component rejection can be bypassed by the BYPAS (pin 12) control. In bypass mode, the DC component of the input analog signal and the internal DC offset are also converted and output in the digital output data.

Table 6. HPF Bypass Control

BYPAS PIN	HPF MODE
Low	Normal (high-pass) mode
High	Bypass (through) mode

OVERFLOW FLAG FOR PCM

The PCM1804-Q1 device has two overflow flag pins, OVFR (pin 20) and OVFL (pin 21). The pins go to high as soon as the analog input goes across the full-scale range. The high level is held for 1.016 s at maximum, and returns to low if the analog input does not go across the full-scale range for the period.

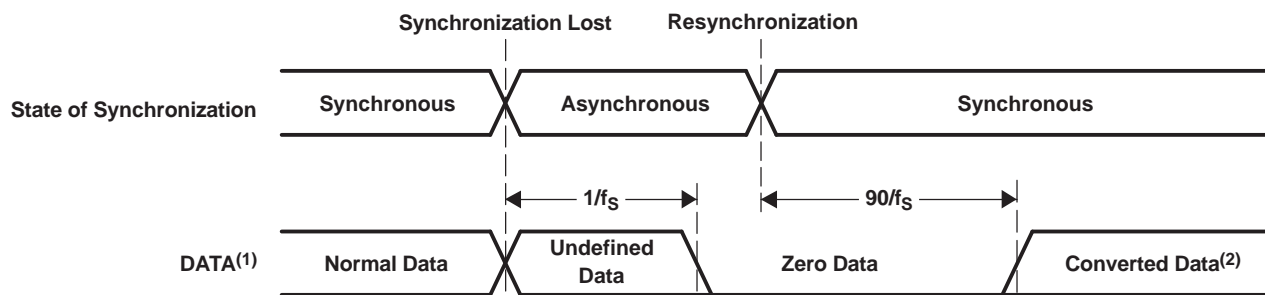

T0020-06

- (1) Applies only for slave mode; the loss of synchronization never occurs in master mode.
- (2) The HPF transient response appears initially.

Figure 41. ADC Digital Output for Loss of Synchronization and Resynchronization

TYPICAL CIRCUIT CONNECTION DIAGRAM

Figure 42 shows a typical circuit connection diagram in the PCM data format operation.

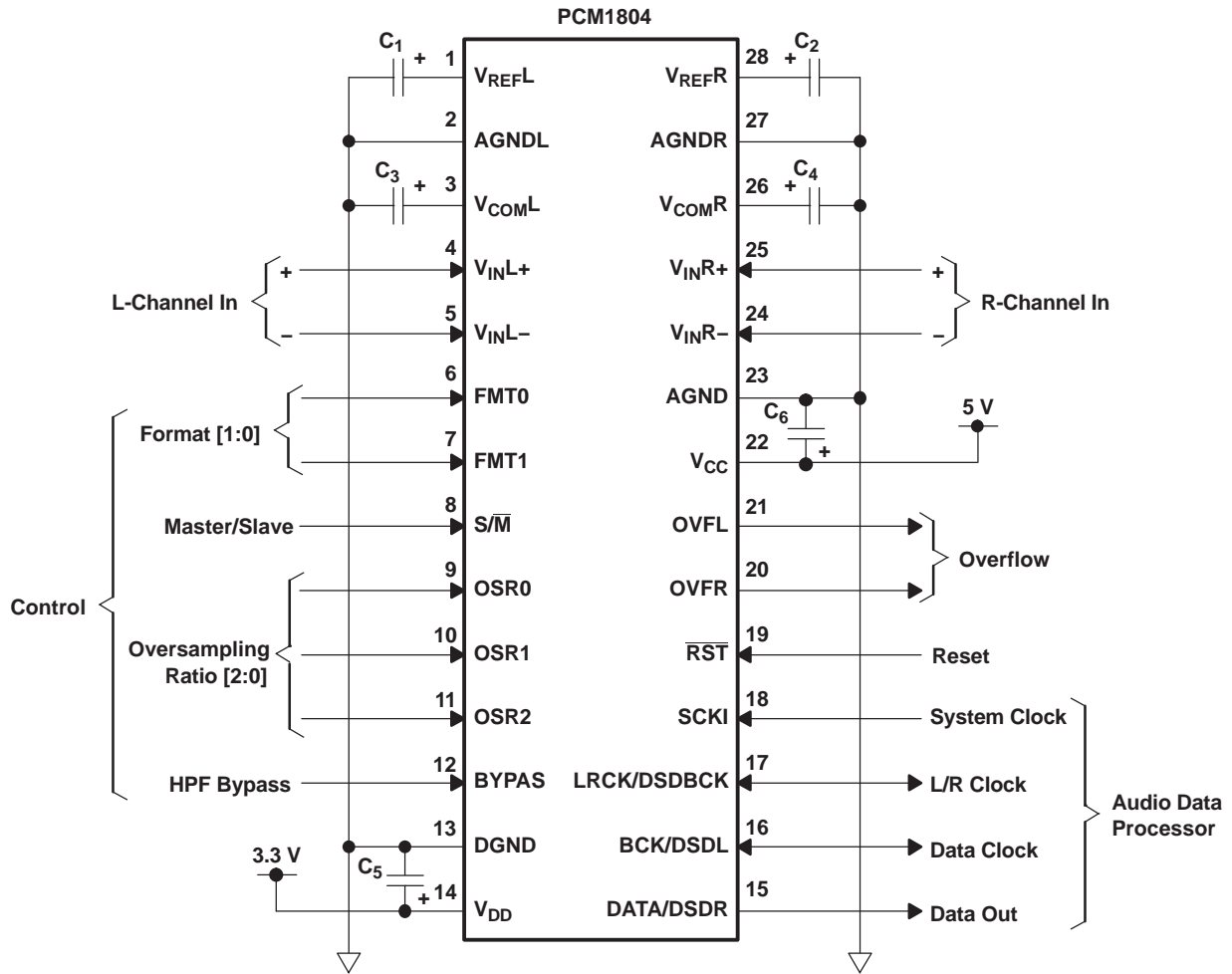

S0058-01

- A. C1, C2, C5, and C6: Bypass capacitors, 0.1- μ F ceramic and 10- μ F tantalum, depending on layout and power supply
- B. C3, C4: Bypass capacitor, 0.1- μ F tantalum, depending on layout and power supply

Figure 42. Typical Circuit Connection Diagram for PCM

Figure 43 shows a typical circuit connection diagram in the DSD data format operation.

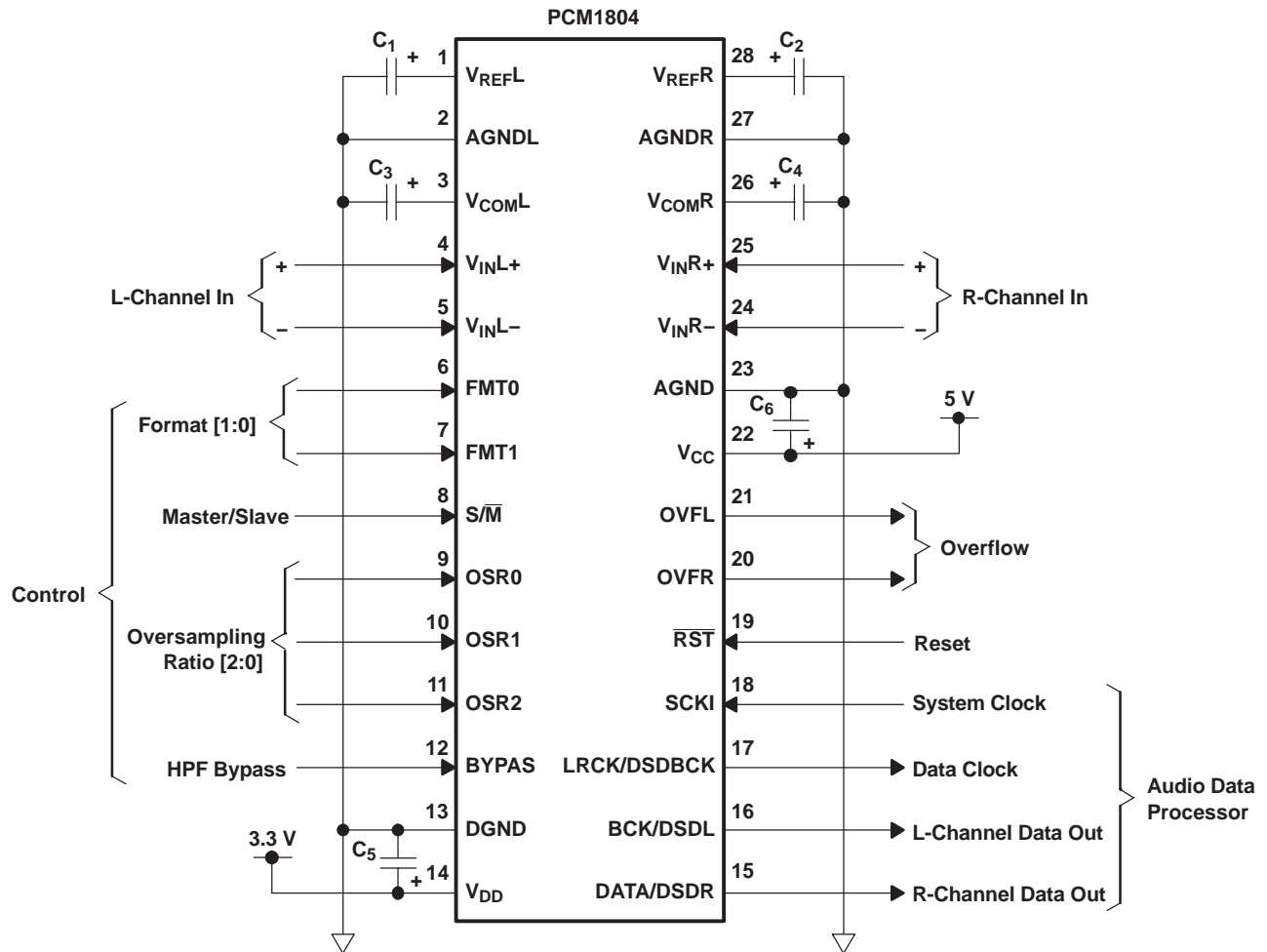

S0058-02

- A. C1, C2, C5, and C6: Bypass capacitors, 0.1- μ F ceramic and 10- μ F tantalum, depending on layout and power supply
- B. C3 and C4: Bypass capacitors, 0.1- μ F tantalum, depending on layout and power supply

Figure 43. Typical Circuit Connection Diagram for DSD

APPLICATION INFORMATION

BOARD DESIGN AND LAYOUT CONSIDERATIONS

V_{CC} and V_{DD} Pins

The digital and analog power supply lines to the PCM1804-Q1 device should be bypassed to the corresponding ground pins with 0.1- μ F ceramic and 10- μ F tantalum capacitors placed as close to the pins as possible to maximize the dynamic performance of the ADC. Although the PCM1804-Q1 device has two power lines to maximize the potential of dynamic performance, using one common power supply is recommended to avoid unexpected power-supply trouble like latch-up or the power-supply sequence.

V_{IN} Pins

Using 0.01- μ F film capacitors between the left-channel analog input positive pin and left-channel analog input negative pin, and between right-channel analog input positive pin and right-channel analog input negative pin is strongly recommended to remove higher-frequency noise from the delta-sigma input section.

V_{REFX} and V_{COMX} Inputs

Use 0.1- μ F ceramic and 10- μ F tantalum capacitors between the left-channel voltage reference output, right-channel voltage reference output, and corresponding analog ground pins, to ensure low source impedance at ADC references. Use 0.1- μ F tantalum capacitors between left-channel analog common-mode voltage, right-channel analog common-mode voltage and corresponding analog ground pins to ensure low source impedance of common voltage. These capacitors should be located as close as possible to the left-channel voltage reference output, right-channel voltage reference output, left-channel analog common-mode voltage, and right-channel analog common-mode voltage pins to reduce dynamic errors on references and common voltage. The DC voltage level of these pins is 2.5 V.

DATA/DSDR, BCK/DSDL, and LRCK/DSDBCK Pins

The DATA/DSDR, BCK/DSDL, and LRCK/DSDBCK pins in master mode have large load drive capability. Locating the buffer near the PCM1804-Q1 device and minimizing the load capacitance, minimizes the digital-analog crosstalk and maximizes the dynamic performance of the ADC.

System Clock

The quality of the system clock can influence dynamic performance because the PCM1804-Q1 device operates based on a system clock. Therefore, it might be necessary to consider the system clock duty, jitter, and the time difference between system clock transition and BCK/DSDL or LRCK/DSDBCK transition in slave mode.

Reset Control

If capacitors larger than 10 μ F are used on left-channel voltage reference output and right-channel voltage reference output, an external reset control with a delay time corresponding to the left-channel voltage reference output and right-channel voltage reference output response is required. Also, it works as a power-down control.

APPLICATION CIRCUIT FOR SINGLE-ENDED INPUT

An application diagram for a single-ended input circuit is shown in [Figure 44](#). The maximum signal input voltage and differential gain of this circuit is designed as $V_{in(max)} = 8.28 V_{pp}$, $A_d = 0.3$. Differential gain (A_d) is given by $R_3 / R_1(R_4 / R_2)$ in a circuit configured as a normal inverted-gain amplifier. Resistor R5 (R6) in the feedback loop gives low-impedance drive operation and noise filtering for the analog input of the PCM1804-Q1 device. The circuit technique using R5 (R6) is recommended.

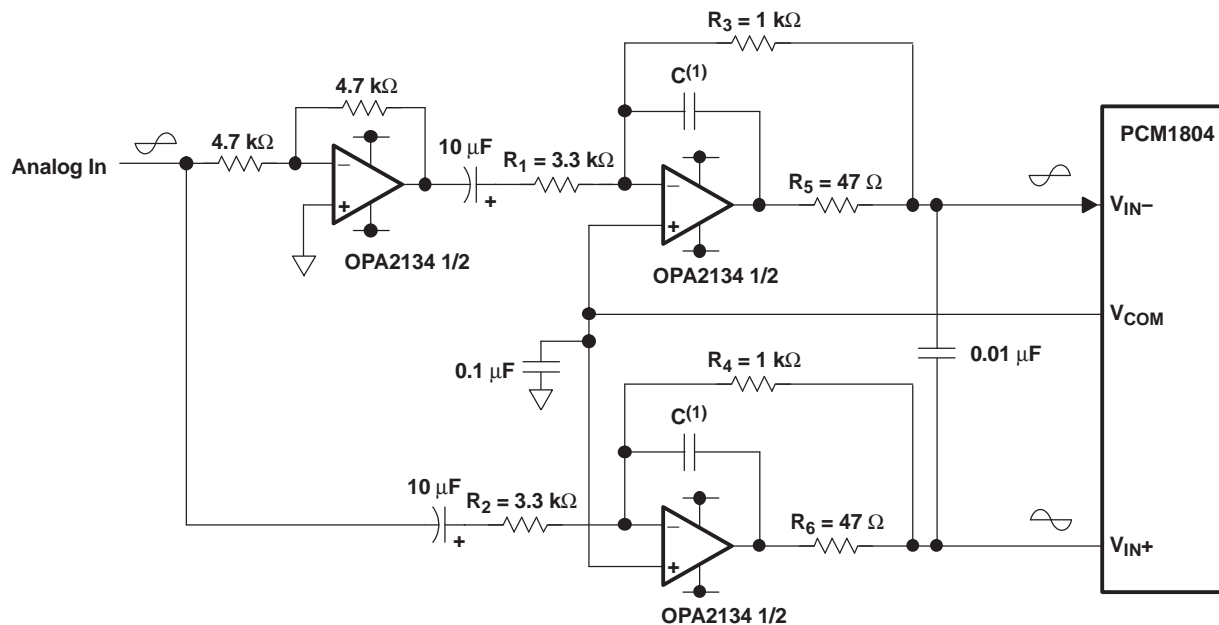

S0059-01

- (1) A capacitor value of 1800 pF is recommended, unless an input signal greater than -6 dBFS at 100 kHz or higher is applied in the DSD mode. In that case, 3300 pF is recommended.

Figure 44. Application Circuit for Single-Ended Input Circuit (PCM)

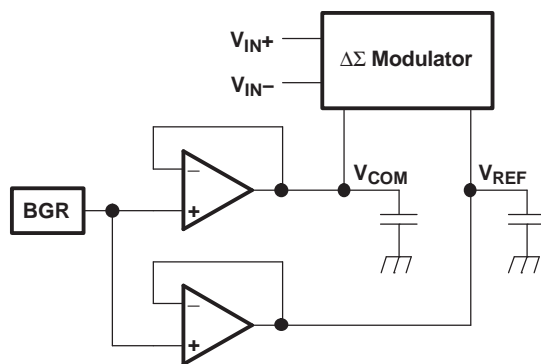

S0060-01

Figure 45. Equivalent Circuit of Internal Reference (V_{COM} , V_{REF})

REVISION HISTORY

Changes from Original (June 2012) to Revision A	Page
• Changed part number from PCM1804-ME to PCM1804-Q1.	1
• Added table note under recommended operating conditions table.	4

PACKAGING INFORMATION

Orderable Device	Status (1)	Package Type	Package Drawing	Pins	Package Qty	Eco Plan (2)	Lead/Ball Finish	MSL Peak Temp (3)	Op Temp (°C)	Device Marking (4/5)	Samples
PCM1804S1IDBRQ1	ACTIVE	SSOP	DB	28	2000	Green (RoHS & no Sb/Br)	CU NIPDAU	Level-3-260C-168 HR	-40 to 85	PCM1804Q	Samples

(1) The marketing status values are defined as follows:

ACTIVE: Product device recommended for new designs.

LIFEBUY: TI has announced that the device will be discontinued, and a lifetime-buy period is in effect.

NRND: Not recommended for new designs. Device is in production to support existing customers, but TI does not recommend using this part in a new design.

PREVIEW: Device has been announced but is not in production. Samples may or may not be available.

OBSOLETE: TI has discontinued the production of the device.

(2) Eco Plan - The planned eco-friendly classification: Pb-Free (RoHS), Pb-Free (RoHS Exempt), or Green (RoHS & no Sb/Br) - please check <http://www.ti.com/productcontent> for the latest availability information and additional product content details.

TBD: The Pb-Free/Green conversion plan has not been defined.

Pb-Free (RoHS): TI's terms "Lead-Free" or "Pb-Free" mean semiconductor products that are compatible with the current RoHS requirements for all 6 substances, including the requirement that lead not exceed 0.1% by weight in homogeneous materials. Where designed to be soldered at high temperatures, TI Pb-Free products are suitable for use in specified lead-free processes.

Pb-Free (RoHS Exempt): This component has a RoHS exemption for either 1) lead-based flip-chip solder bumps used between the die and package, or 2) lead-based die adhesive used between the die and leadframe. The component is otherwise considered Pb-Free (RoHS compatible) as defined above.

Green (RoHS & no Sb/Br): TI defines "Green" to mean Pb-Free (RoHS compatible), and free of Bromine (Br) and Antimony (Sb) based flame retardants (Br or Sb do not exceed 0.1% by weight in homogeneous material)

(3) MSL, Peak Temp. -- The Moisture Sensitivity Level rating according to the JEDEC industry standard classifications, and peak solder temperature.

(4) There may be additional marking, which relates to the logo, the lot trace code information, or the environmental category on the device.

(5) Multiple Device Markings will be inside parentheses. Only one Device Marking contained in parentheses and separated by a "-" will appear on a device. If a line is indented then it is a continuation of the previous line and the two combined represent the entire Device Marking for that device.

Important Information and Disclaimer:The information provided on this page represents TI's knowledge and belief as of the date that it is provided. TI bases its knowledge and belief on information provided by third parties, and makes no representation or warranty as to the accuracy of such information. Efforts are underway to better integrate information from third parties. TI has taken and continues to take reasonable steps to provide representative and accurate information but may not have conducted destructive testing or chemical analysis on incoming materials and chemicals. TI and TI suppliers consider certain information to be proprietary, and thus CAS numbers and other limited information may not be available for release.

In no event shall TI's liability arising out of such information exceed the total purchase price of the TI part(s) at issue in this document sold by TI to Customer on an annual basis.

OTHER QUALIFIED VERSIONS OF PCM1804-Q1 :

- Catalog: [PCM1804](#)

NOTE: Qualified Version Definitions:

- Catalog - TI's standard catalog product

TAPE AND REEL INFORMATION

QUADRANT ASSIGNMENTS FOR PIN 1 ORIENTATION IN TAPE

*All dimensions are nominal

Device	Package Type	Package Drawing	Pins	SPQ	Reel Diameter (mm)	Reel Width W1 (mm)	A0 (mm)	B0 (mm)	K0 (mm)	P1 (mm)	W (mm)	Pin1 Quadrant
PCM1804S1IDBRQ1	SSOP	DB	28	2000	330.0	16.4	8.2	10.5	2.5	12.0	16.0	Q1

TAPE AND REEL BOX DIMENSIONS



*All dimensions are nominal

Device	Package Type	Package Drawing	Pins	SPQ	Length (mm)	Width (mm)	Height (mm)
PCM1804S1IDBRQ1	SSOP	DB	28	2000	367.0	367.0	38.0

DB (R-PDSO-G**)

PLASTIC SMALL-OUTLINE

28 PINS SHOWN



- NOTES: A. All linear dimensions are in millimeters.
 B. This drawing is subject to change without notice.
 C. Body dimensions do not include mold flash or protrusion not to exceed 0,15.
 D. Falls within JEDEC MO-150

IMPORTANT NOTICE

Texas Instruments Incorporated and its subsidiaries (TI) reserve the right to make corrections, enhancements, improvements and other changes to its semiconductor products and services per JESD46, latest issue, and to discontinue any product or service per JESD48, latest issue. Buyers should obtain the latest relevant information before placing orders and should verify that such information is current and complete. All semiconductor products (also referred to herein as "components") are sold subject to TI's terms and conditions of sale supplied at the time of order acknowledgment.

TI warrants performance of its components to the specifications applicable at the time of sale, in accordance with the warranty in TI's terms and conditions of sale of semiconductor products. Testing and other quality control techniques are used to the extent TI deems necessary to support this warranty. Except where mandated by applicable law, testing of all parameters of each component is not necessarily performed.

TI assumes no liability for applications assistance or the design of Buyers' products. Buyers are responsible for their products and applications using TI components. To minimize the risks associated with Buyers' products and applications, Buyers should provide adequate design and operating safeguards.

TI does not warrant or represent that any license, either express or implied, is granted under any patent right, copyright, mask work right, or other intellectual property right relating to any combination, machine, or process in which TI components or services are used. Information published by TI regarding third-party products or services does not constitute a license to use such products or services or a warranty or endorsement thereof. Use of such information may require a license from a third party under the patents or other intellectual property of the third party, or a license from TI under the patents or other intellectual property of TI.

Reproduction of significant portions of TI information in TI data books or data sheets is permissible only if reproduction is without alteration and is accompanied by all associated warranties, conditions, limitations, and notices. TI is not responsible or liable for such altered documentation. Information of third parties may be subject to additional restrictions.

Resale of TI components or services with statements different from or beyond the parameters stated by TI for that component or service voids all express and any implied warranties for the associated TI component or service and is an unfair and deceptive business practice. TI is not responsible or liable for any such statements.

Buyer acknowledges and agrees that it is solely responsible for compliance with all legal, regulatory and safety-related requirements concerning its products, and any use of TI components in its applications, notwithstanding any applications-related information or support that may be provided by TI. Buyer represents and agrees that it has all the necessary expertise to create and implement safeguards which anticipate dangerous consequences of failures, monitor failures and their consequences, lessen the likelihood of failures that might cause harm and take appropriate remedial actions. Buyer will fully indemnify TI and its representatives against any damages arising out of the use of any TI components in safety-critical applications.

In some cases, TI components may be promoted specifically to facilitate safety-related applications. With such components, TI's goal is to help enable customers to design and create their own end-product solutions that meet applicable functional safety standards and requirements. Nonetheless, such components are subject to these terms.

No TI components are authorized for use in FDA Class III (or similar life-critical medical equipment) unless authorized officers of the parties have executed a special agreement specifically governing such use.

Only those TI components which TI has specifically designated as military grade or "enhanced plastic" are designed and intended for use in military/aerospace applications or environments. Buyer acknowledges and agrees that any military or aerospace use of TI components which have **not** been so designated is solely at the Buyer's risk, and that Buyer is solely responsible for compliance with all legal and regulatory requirements in connection with such use.

TI has specifically designated certain components as meeting ISO/TS16949 requirements, mainly for automotive use. In any case of use of non-designated products, TI will not be responsible for any failure to meet ISO/TS16949.

Products

Audio	www.ti.com/audio
Amplifiers	amplifier.ti.com
Data Converters	dataconverter.ti.com
DLP® Products	www.dlp.com
DSP	dsp.ti.com
Clocks and Timers	www.ti.com/clocks
Interface	interface.ti.com
Logic	logic.ti.com
Power Mgmt	power.ti.com
Microcontrollers	microcontroller.ti.com
RFID	www.ti-rfid.com
OMAP Applications Processors	www.ti.com/omap
Wireless Connectivity	www.ti.com/wirelessconnectivity

Applications

Automotive and Transportation	www.ti.com/automotive
Communications and Telecom	www.ti.com/communications
Computers and Peripherals	www.ti.com/computers
Consumer Electronics	www.ti.com/consumer-apps
Energy and Lighting	www.ti.com/energy
Industrial	www.ti.com/industrial
Medical	www.ti.com/medical
Security	www.ti.com/security
Space, Avionics and Defense	www.ti.com/space-avionics-defense
Video and Imaging	www.ti.com/video

TI E2E Community

e2e.ti.com